

Service

Workshop Manual

Volkswagen

Industrial engine

4-Cyl. Diesel engine (1.9 ltr engine)

Edition January 1994



Hako-Citymaster 1750

Service department

Service.



List of Workshop Manual Repair Groups Volkswagen, Industrial engine

Engine code	028.B	ADE	ADG						
-------------	-------	-----	-----	--	--	--	--	--	--

Booklet 4-Cyl Diesel engine (1.9 ltr engine)
Edition January 1994

When filing a Technical Bulletin enter the Bulletin No. in the adjacent column. When using the Workshop Manual you can then see at a glance whether Technical Bulletins have been published in respect of the particular Repair Group in which you are looking.

Repair Group	Technical Bulletins					
00 Technical Data						
10 Removing and installing engine						
13 Crankshaft group						
15 Cylinder head, Valve gear						
17 Lubrication						
19 Cooling						
21 Charging						
23 Mixture preparation, Injection						
27 Starter, Current supply						
28 Glow plug system						

Technical Information should always be available to all foremen and mechanics, because their compliance with the instructions given is essential to ensure vehicle roadworthiness and safety. In addition, the normal safety precautions to be observed when working on motor vehicles are also applicable.

This Workshop Manual is only intended for use within the Volkswagen and Audi organisation, passing on to third parties is not permitted.

Printed in Germany

Contents

00	Technical data	Page
	Technical data	00-1
	- Engine number	00-1
	- Engine characteristics	00-2
10	Removing and installing engine	Page
	Removing and installing engine	10-1
	- Instructions for removing	10-1
	- Instructions for installing	10-1
	- Tightening torques	10-2
13	Crankshaft group	Page
	Dismantling and assembling engine	13-1
	- Adjusting alternator V- belt	13-12
	- Removing and installing toothed belt	13-13
	- Tensioning toothed belt	13-15
	- Removing injection pump sprocket	13-16
	Dismantling and assembling cylinder block, crankshaft and flywheel	13-17
	- Renewing crankshaft seal – pulley end	13-25
	- Crankshaft dimensions	13-27
	Dismantling and assembling pistons and conrods	13-28
	- Checking piston position at TDC	13-34
	- Piston and cylinder dimensions	13-35
15	Cylinder head, valve gear	Page
	Removing and installing cylinder head	15-1
	- Installing cylinder head	15-7
	- Checking compression pressure	15-9
	Servicing valve gear	15-11
	- Reworking valve seats	15-17
	- Checking valve guides	15-19
	- Renewing valve guides	15-19
	- Renewing valve stem seals	15-20
	- Removing and installing camshaft	15-21
	- Checking hydraulic bucket tappets	15-22
17	Lubrication	Page
	Removing and installing parts of lubrication system	17-1
	- Checking oil pressure and oil pressure switch	17-7
19	Cooling	Page
	Removing and installing parts of cooling system	19-1
	- Cooling system parts – engine side	19-2
	- Coolant hose connection diagram	19-5
	- Draining and filling with coolant	19-6
21	Charging	Page
	Removing and installing parts of exhaust gas charging	21-1
	- Rules for cleanliness	21-4
	- Removing and installing exhaust gas turbo charger	21-5
	- Checking turbo charger	21-6
23	Mixture preparation, injection	Page
	Servicing fuel injection system	23-1
	- Removing and installing fuel filter	23-6
	- Rules for cleanliness	23-9
	- Adjusting cold start accelerator operating cable	23-10
	- Removing and installing injection pump	23-11

- Checking and adjusting injection pump commencement of injection	23-15
- Checking and adjusting valve timing	23-18
- Sealing injection pump connections	23-20
- Checking and adjusting idling and governed speeds	23-20
- Removing and installing injectors	23-22
- Servicing injectors	23-23

27 Starter, Current supply

Page

Checking alternator and voltage regulator with ballast resistance	27-1
Checking starter	27-4
- Starter does not turn	27-4
- Starter turns too slowly and does not crank engine	27-5
- Current flow diagram 12V, 24V	27-7

28 Glow plug system

Page

Checking glow plug system	28-1
- Checking glow plug current draw with V.A.G. 1315A	28-1
- Checking glow plugs	28-3
- Glow plugs with burnt electrodes	28-4

Technical Data

Engine Number

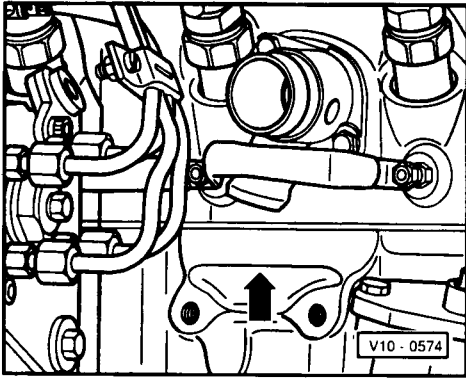

- ◀ The engine number (engine code and "serial number") is stamped on the left-hand side of the cylinder block - arrow -.

00-1

Engine Data

Engine Type		028.B	ADG	ADE
Manufactured		04.90...02.94	03.94 ➤	01.94 ➤
Cylinders	No.	4	4	4
Displacement	ltrs	1.9	1.9	1.9
Output ¹⁾	kW at rpm	43/4000	43/4000	56/4000
Torque	Nm at rpm	120/1800...3000	120/1800...3000	154/1800...3000
Bore	Ø mm	79.5	79.5	79.5
Stroke	mm	95.5	95.5	95.5
Compression ratio		23:1	23:1	23:1
CN	min.	45	45	45
Firing order		1-3-4-2	1-3-4-2	1-3-4-2
Normally aspirated diesel		x	x	-
Turbocharged diesel		-	-	x

¹⁾ Engine output varies according to the use to which the engine is to be put and the fuel injection pump setting.

00-2

Removing and installing engine

Note:

The following section contains only general instructions for the removal and installation of industrial engines, since, due to the different installation methods, no working sequence, which is generally applicable, can be given.

Instructions for removing

- With ignition turned off disconnect battery earth strap.
- Remove cap from expansion tank or radiator and drain coolant into a suitable container.
- Disconnect electrical wiring.
- Disconnect Bowden cables, such as clutch cable, accelerator cable and cold start accelerator cable.
- Detach fuel supply and return pipes.

Instructions for installing

- If the fuel pipes have been detached at the injection pump, ensure that the unions for fuel supply and return pipes are not interchanged. The return pipe has a smaller inside diameter and is marked with "OUT" on the hexagonal head.

10-1

- Align engine mountings stress free by rocking engine.
- Fill with coolant ⇒ Page 19-6.
- Adjust cold start accelerator cable ⇒ Page 23-10.
- If necessary, adjust clutch free play.

Tightening torques

Bolted connections		Tightening torque
On cylinder block	M8	25 Nm
	M10	45 Nm
	M12	55 Nm
Front exhaust pipe to exhaust manifold/turbo charger		25 Nm

10-2

Dismantling and assembling engine

Note:

- ♦ If, when repairing an engine, a large quantity of swarf or fine metal particles as caused e.g. by seizure of crankshaft and conrod bearings is found in the engine oil, the oil drillings must be thoroughly cleaned and the oil cooler replaced to prevent subsequent damage.
- ♦ Defective injectors can cause violent knocking in the engine which sounds like damaged bearings. If this happens, run the engine at idling speed and slacken off the injection pipe unions one after the other. If the knocking stops after loosening a union, this indicates that this injector is defective.

Servicing injectors
 ⇒ Page 23-23.

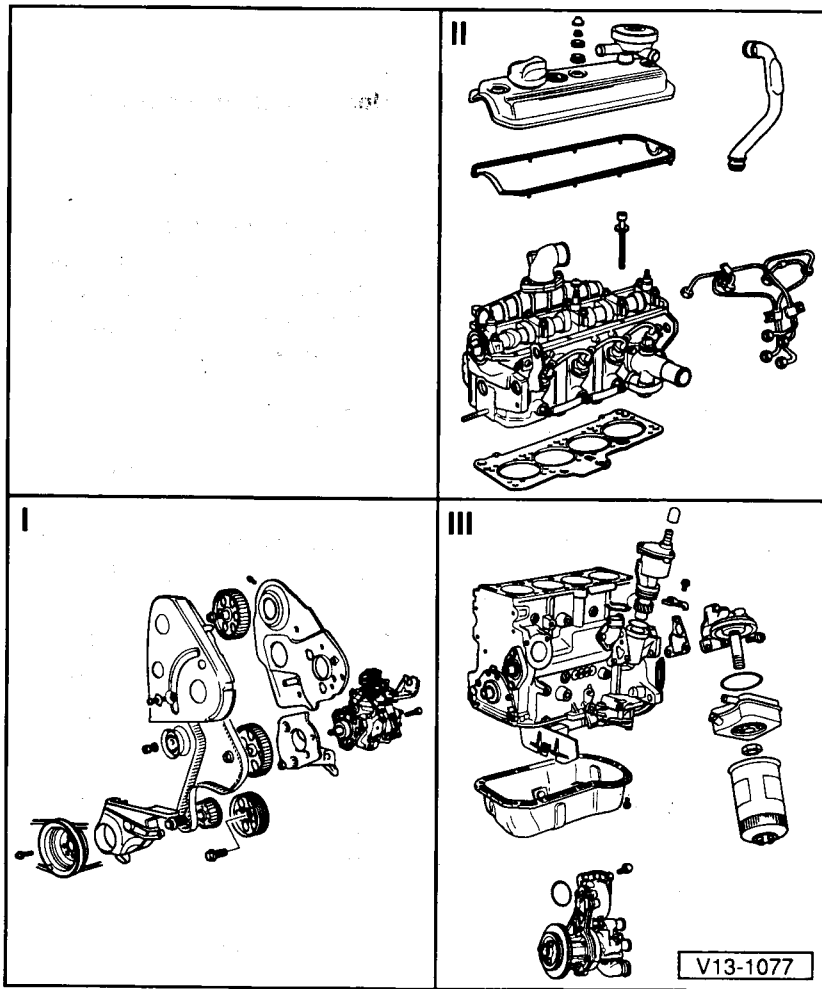

13-1

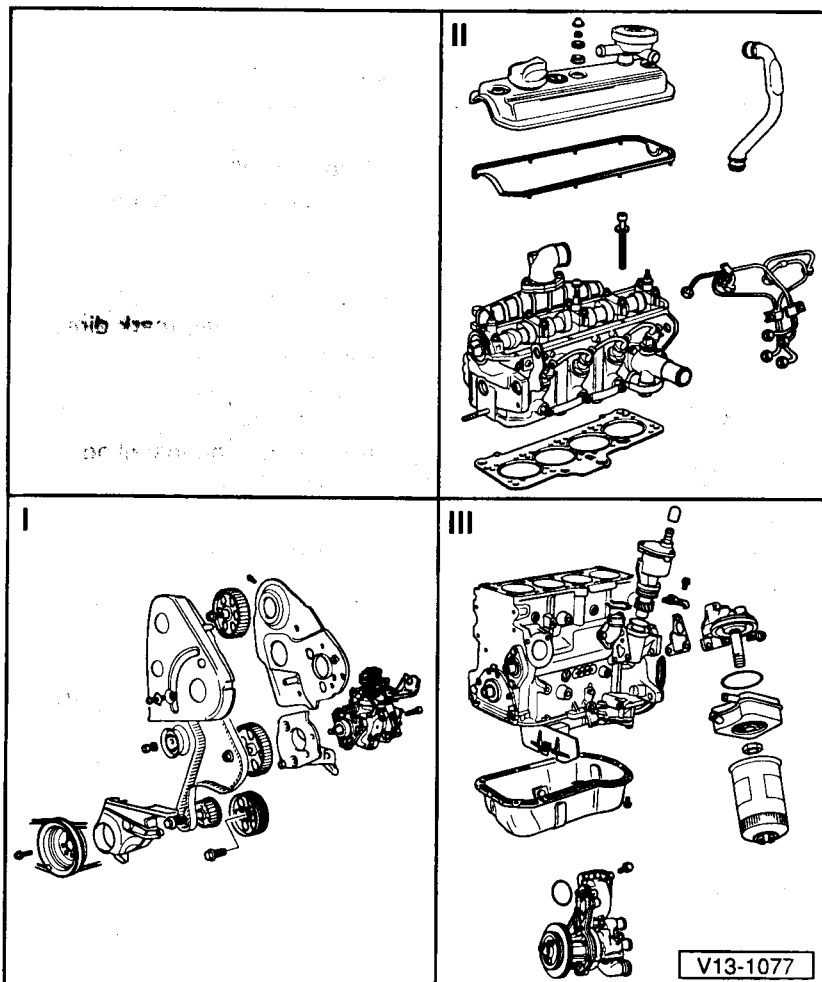

I ⇒ Page 13-3.

II ⇒ Page 13-7.

III ⇒ Page 13-10.

13-2

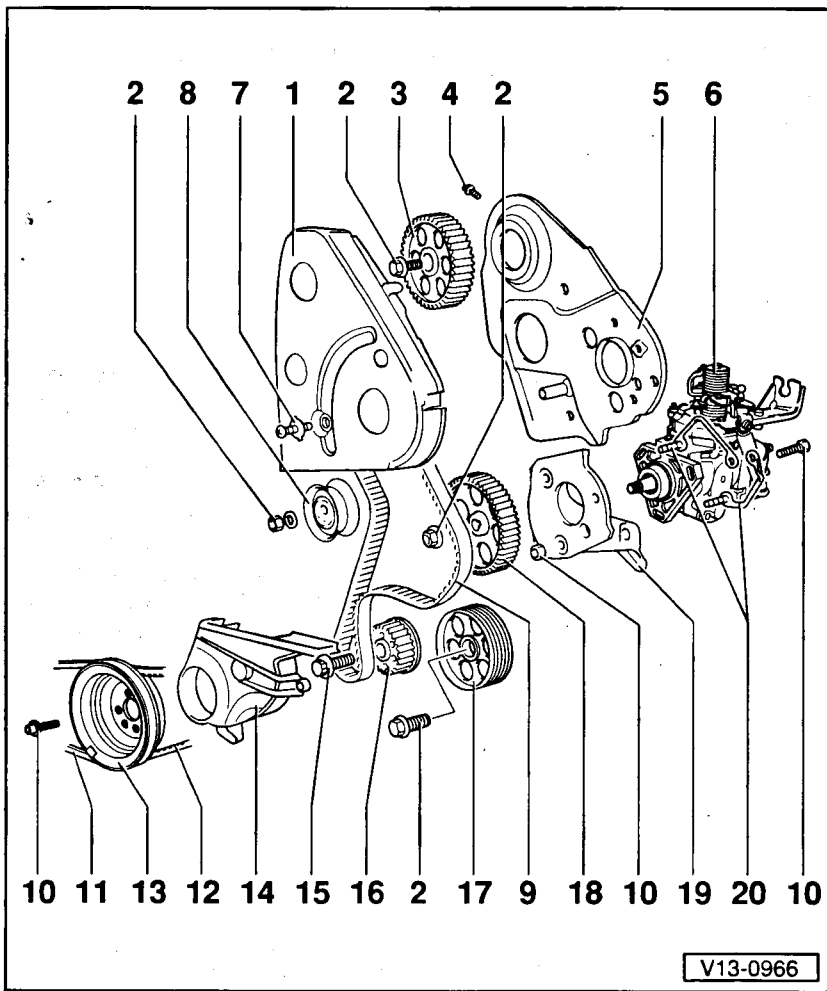

Part I

- 1 - Upper toothed belt guard**
- 2 - 45 Nm**
- 3 - Camshaft sprocket**
 - ♦ Loosen from taper on camshaft by striking a drift through the hole in the toothed belt guard with a hammer
- 4 - 10 Nm**
- 5 - Rear toothed belt guard**
- 6 - Injection pump**
 - ♦ Removing and installing ⇒ Page 23-11
 - ♦ Checking and adjusting commencement of injection ⇒ Page 23-15
 - ♦ Sealing connections ⇒ Page 23-20
 - ♦ Checking and adjusting idling and governed speeds ⇒ Page 23-20

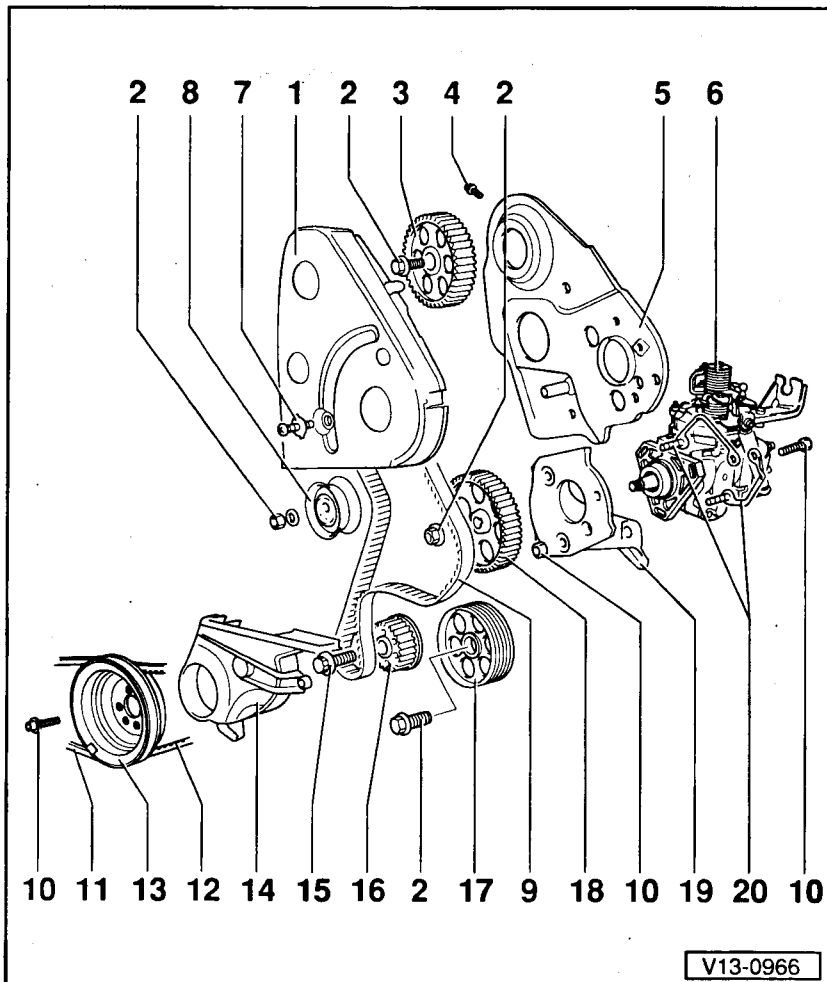

- 7 - Expanding clip**
 - ♦ Loosen with coin
- 8 - Tensioning roller**
 - ♦ Tensioning toothed belt ⇒ Page 13-15
- 9 - Toothed belt**
 - ♦ Before removal, mark direction of rotation
 - ♦ Check for wear
 - ♦ Do not kink
 - ♦ Removing, and installing ⇒ Page 13-13
 - ♦ Tensioning ⇒ Page 13-15
- 10 - 25 Nm**
- 11 - Alternator V-belt**
 - ♦ Check tension with thumb pressure max. deflection:
new belt approx. 2 mm
used belt approx. 5 mm
 - ♦ Adjusting ⇒ Page 13-12

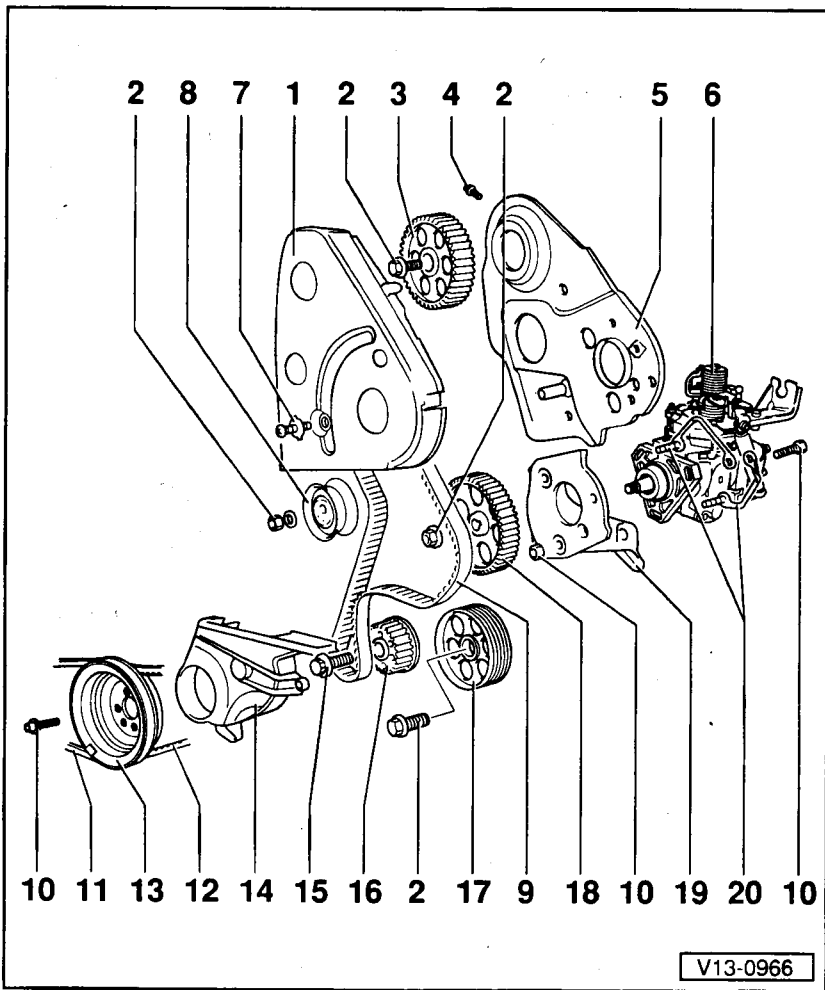

- 12 - Coolant pump V-belt**
- ♦ Check tension with thumb pressure max. deflection: new belt approx. 2 mm used belt approx. 5 mm
 - ♦ Adjusting ⇒ Page 19-2, Parts of cooling system engine side

13 - Double pulley

14 - Lower toothed belt guard

- 15 - 90 Nm + ¼ turn (90°) further**
- ♦ Renew
 - ♦ Use counter-hold tool 3099 when loosening and tightening
 - ♦ Oil threads and contact surface
 - ♦ Turning further can be done in several stages

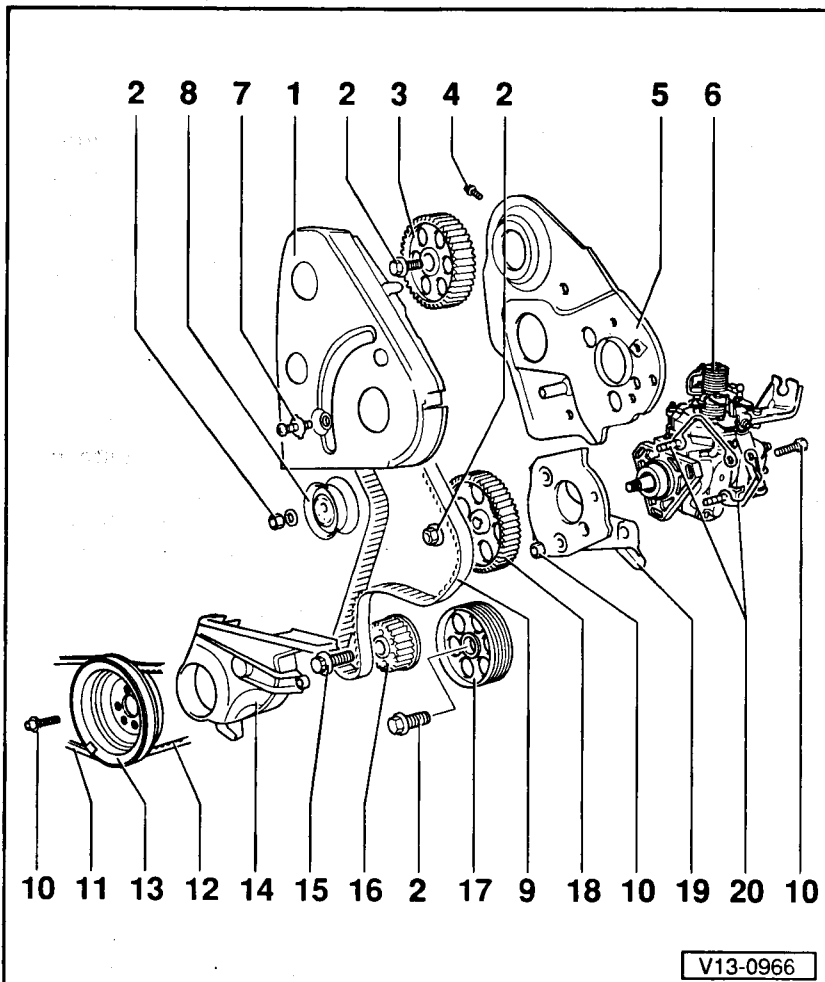

16 - Crankshaft toothed belt sprocket

17 - Intermediate shaft pulley

18 - Injection pump sprocket

- ♦ Removing ⇒ Page 13-16

19 - Console

20 - Retainer

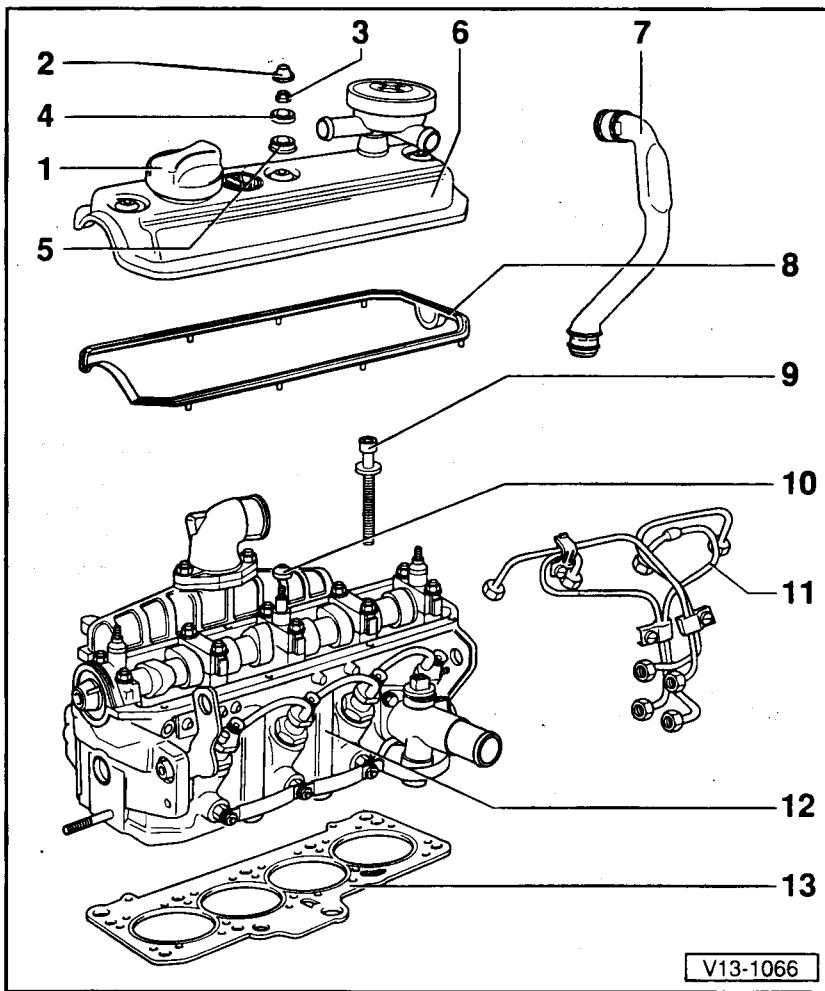

Part II

- 1 - Oil filler cap
 - ♦ Renew seal if damaged
- 2 - Cover cap
- 3 - 10 Nm
- 4 - Dished washer
- 5 - Upper sealing washer
 - ♦ Renew if damaged
- 6 - Cylinder head cover
- 7 - Crankcase breather
- 8 - Gasket for cylinder head cover
 - ♦ Renew if damaged
 - ♦ Insert lugs into the drillings in cylinder head

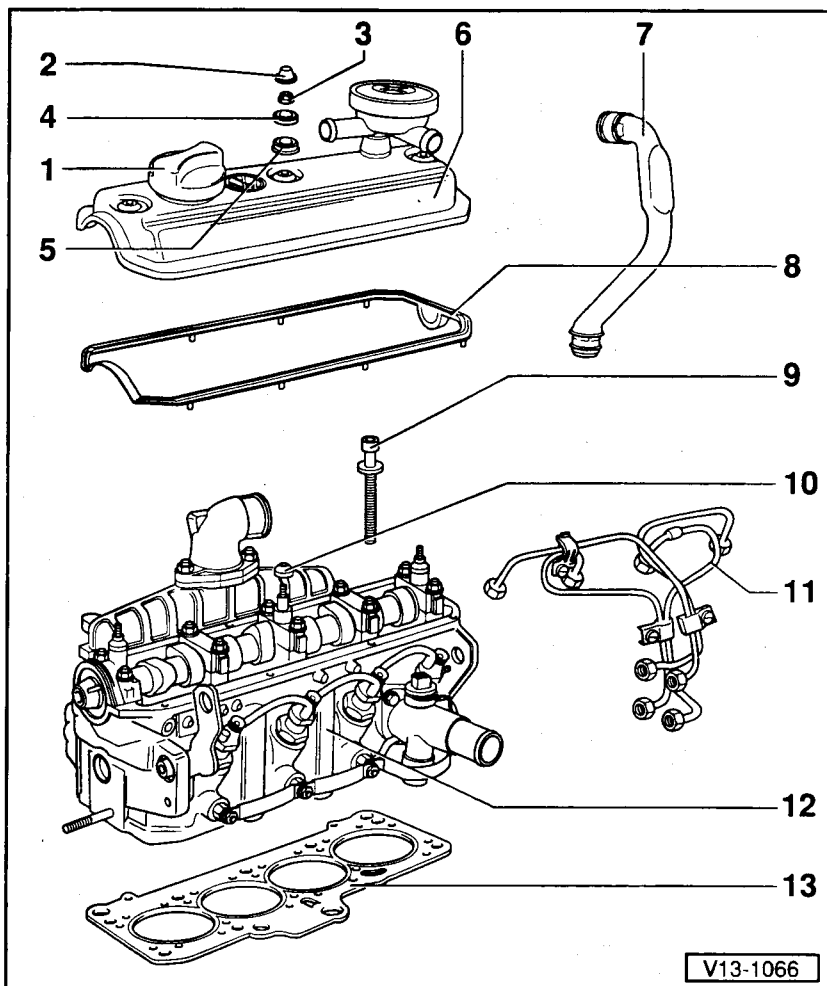

- 9 - Cylinder head bolt
 - ♦ Renew
 - ♦ Note installation instructions and sequence when loosening and tightening
 - ⇒ Page 15-7
- 10 - Conical lower sealing washer
 - ♦ Renew if damaged
- 11 - Injection pipes
 - ♦ Tighten to 25 Nm
 - ♦ Remove and install with open ring spanner
 - ♦ Always remove pipe set complete
 - ♦ Do not alter shape
- 12 - Cylinder head
 - ♦ Removing and installing
 - ⇒ Page 15-1
 - ♦ After renewing always renew complete coolant

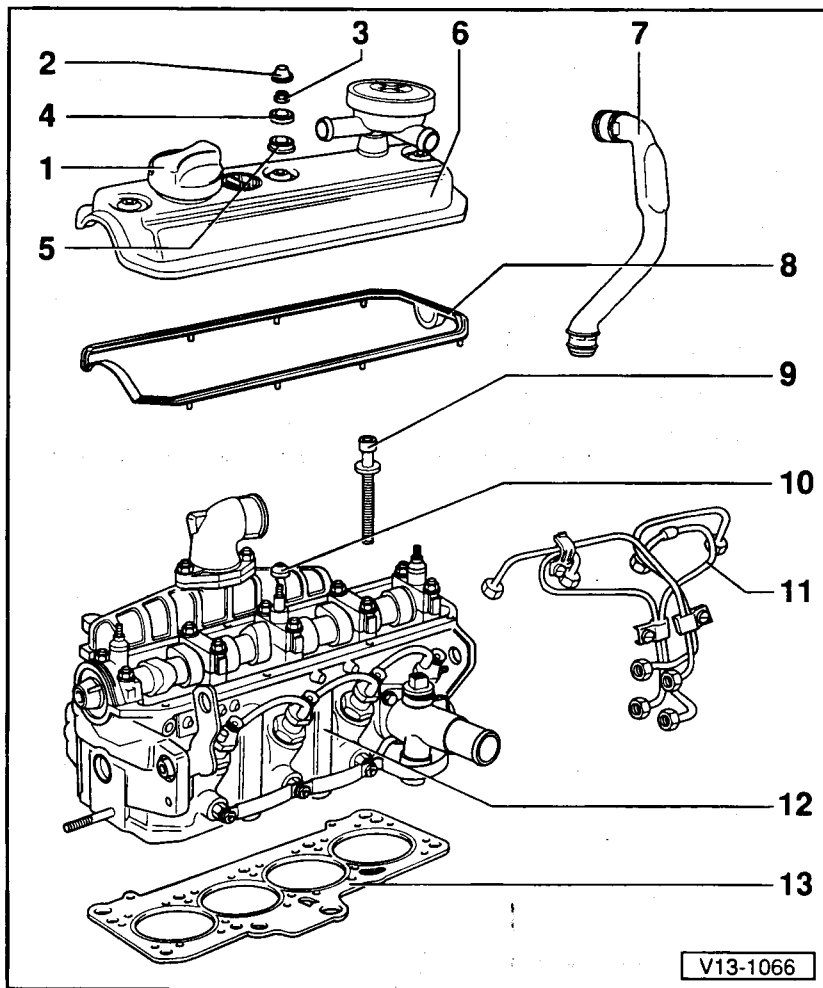

V13-1066

13 - Cylinder head gasket

- ♦ Renew
- ♦ Observe markings
⇒ Page 13-34
- ♦ After renewing always renew complete coolant

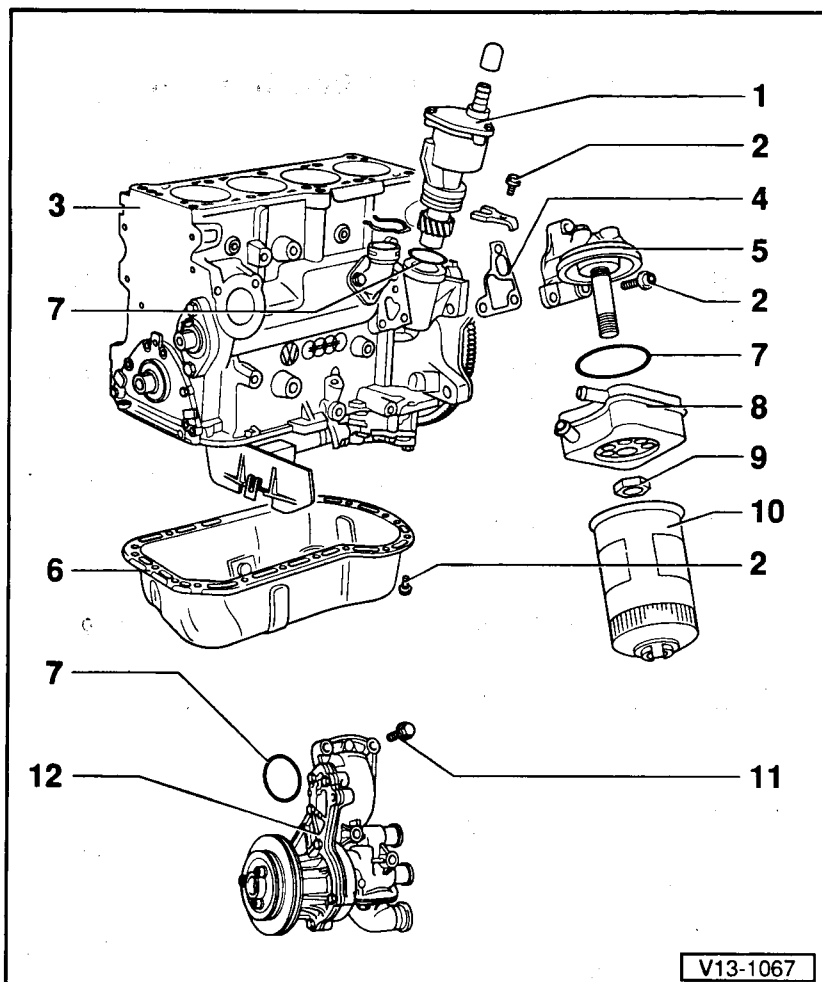

V13-1067

Part III

- 1 - Vacuum pump**
- 2 - 20 Nm**
- 3 - Cylinder block**
 - ♦ Dismantling and assembling cylinder block, crankshaft and flywheel
⇒ Page 13-17
- 4 - Gasket**
 - ♦ Renew
- 5 - Oil filter bracket**
- 6 - Sump**
 - ♦ Clean contact surfaces before fitting
- 7 - O-ring**
 - ♦ Renew

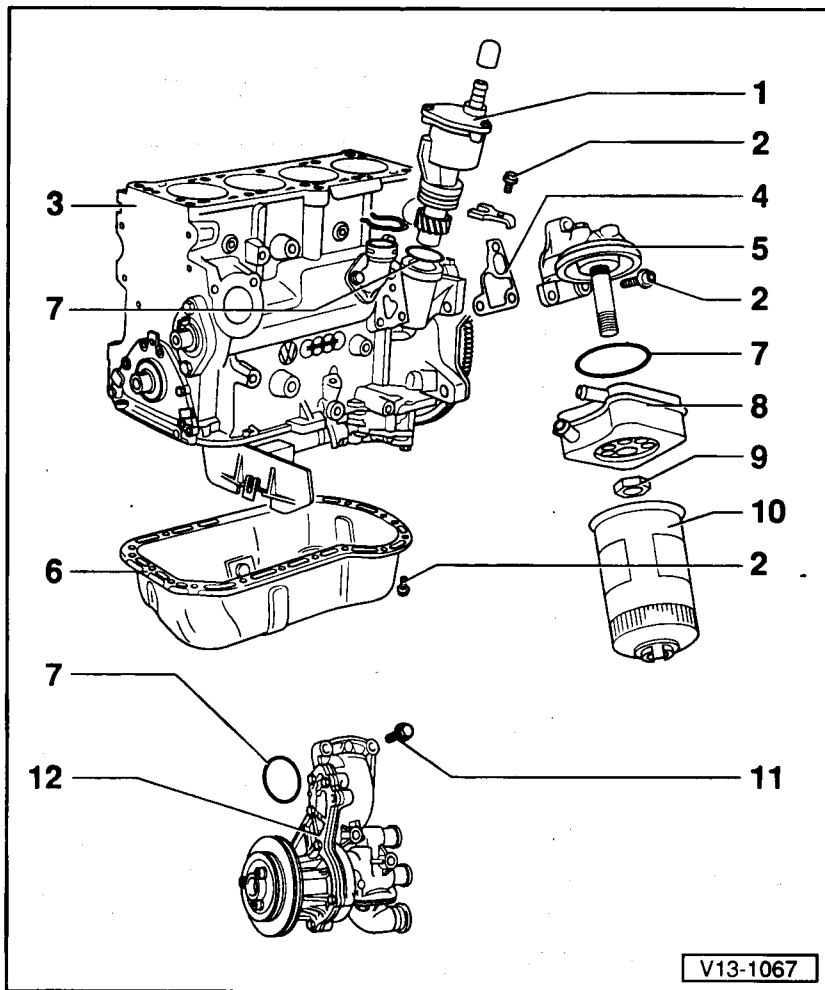

- 8 - Oil cooler
 - ♦ Coat contact surfaces outside the sealing ring with AMV 188 100 02
 - ♦ Ensure clearance from adjacent components
 - ♦ See Note ⇒ Page 13-1

9 - 20 Nm

- 10 - Oil filter
 - ♦ Loosen with strap wrench
 - ♦ Tighten by hand
 - ♦ Observe installation instructions on oil filter

11 - 25 Nm

- 12 - Coolant pump
 - ♦ Check that shaft rotates freely

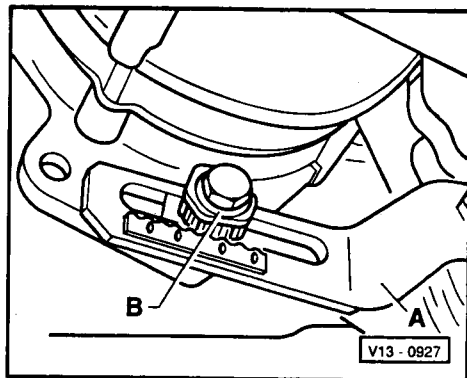

Adjusting alternator V-belt tension

- ◀ - Slacken off all securing bolts for tensioning bracket - A- and alternator at least 1 turn.

Note:

The alternator must be easily movable by hand.

- Tension V-belt by turning the tensioning nut -B- with a torque wrench

Specifications:

New V-belt 8 Nm

Used V-belt 4 Nm

then tighten tensioning nut locking bolt to 30 Nm.

- Tighten all tensioning bracket and alternator securing bolts.

Note:

The torque wrench V.A.G. 1410 in conjunction with 22 mm socket spanner V.A.G. 1410/2 is particularly suitable for this adjustment.

Removing, and installing toothed belt

Removing

- Remove alternator and coolant pump V-belts.
- Remove upper toothed belt guard and cylinder head cover.

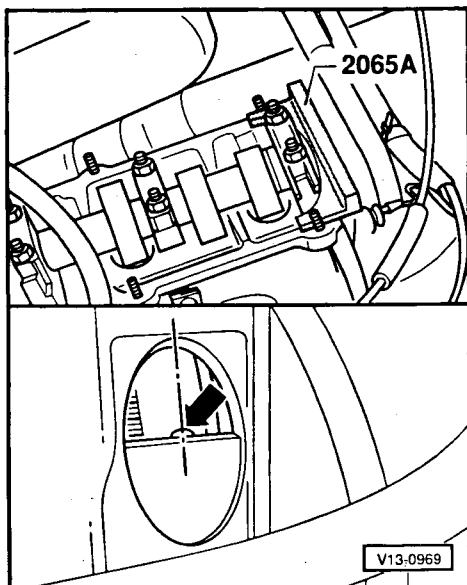

- ◀ - Turn crankshaft to TDC No. 1 cylinder -arrow-.
- Lock camshaft with setting jig 2065A.
- Align setting jig as follows:
Turn locked camshaft until one end of setting jig contacts the cylinder head. Measure gap at other end of setting jig with feeler gauges. Place feeler gauge with half of this dimension between setting jig and cylinder head. Turn camshaft until the setting jig contacts the feeler gauge. Place a second feeler gauge of same size between other end of setting jig and cylinder head.

13-13

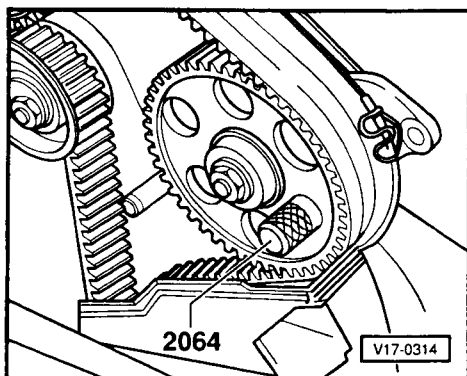

- ◀ - Lock the injection pump sprocket in this position with pin 2064.
- Loosen tensioning roller.
- Remove vibration damper and pulley.
- Remove lower part of toothed belt guard.
- Mark the direction of rotation of the toothed belt.
- Remove toothed belt.

Installing

- Check that TDC mark on flywheel aligns with reference mark.
- Loosen camshaft sprocket securing bolt $\frac{1}{2}$ a turn. Loosen camshaft sprocket from taper on camshaft by striking with hammer (using drift through the hole in the rear toothed belt guard).
- Install toothed belt (observe direction of rotation) and remove pin from injection pump sprocket.
- ◀ - Tension toothed belt. (Rotate tensioning roller to the right using a pin wrench, e.g. Matra V159 - arrow -).
Scale value: 12...13
measured between camshaft sprocket and injection pump sprocket.

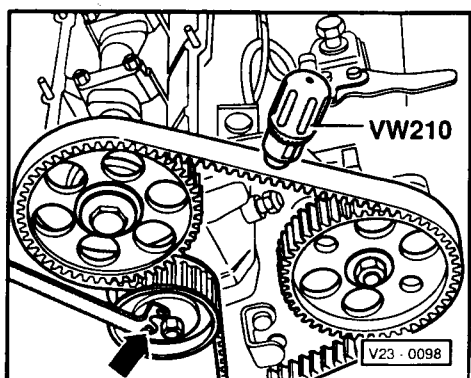

13-14

- Tighten camshaft sprocket securing nut to 45 Nm.
- Remove setting jig.
- Turn crankshaft two turns in engine direction of rotation and again check that toothed belt tension is to specification.
- Install belt pulley, toothed belt guard and cylinder head cover.
- Check injection pump commencement of injection
⇒ Page 23-15.

Tensioning toothed belt

- Remove toothed belt guard upper part.

- ◀ - Using tester VW 210 check and note toothed belt tension between camshaft sprocket and injection pump sprocket.
- Turn crankshaft one full turn and repeat check.
- Compare average value of checks 1 and 2 with specification.
Specification: Scale value 12...13
- If necessary tension toothed belt to specification on tensioning roller (by turning to right with pin wrench e.g. Matra V 159 - arrow-).

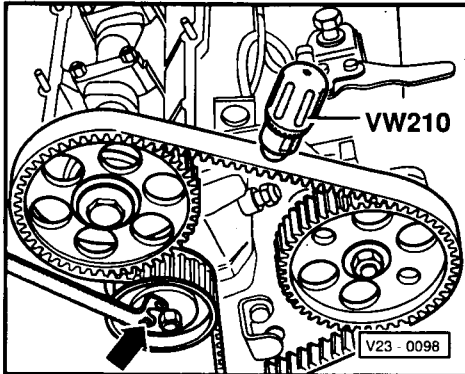

13-15

- Fit toothed belt guard.

Removing injection pump sprocket

- Loosen injection pump sprocket securing nut.

- ◀ - Loosen puller arms and fit puller.
- Align arms to holes in injection pump sprocket and tighten.
- Place injection pump sprocket under tension with puller.
- Loosen injection pump sprocket from taper on shaft by tapping lightly with a hammer on the spindle of the puller -arrow- (when doing this hold sprocket to prevent it falling down).

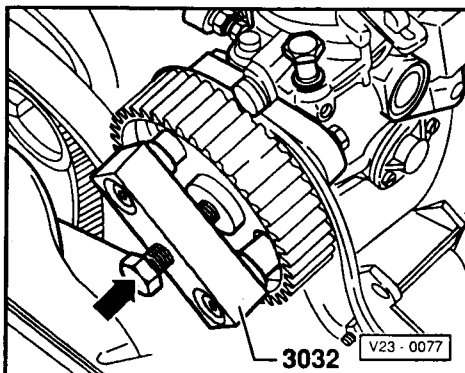

13-16

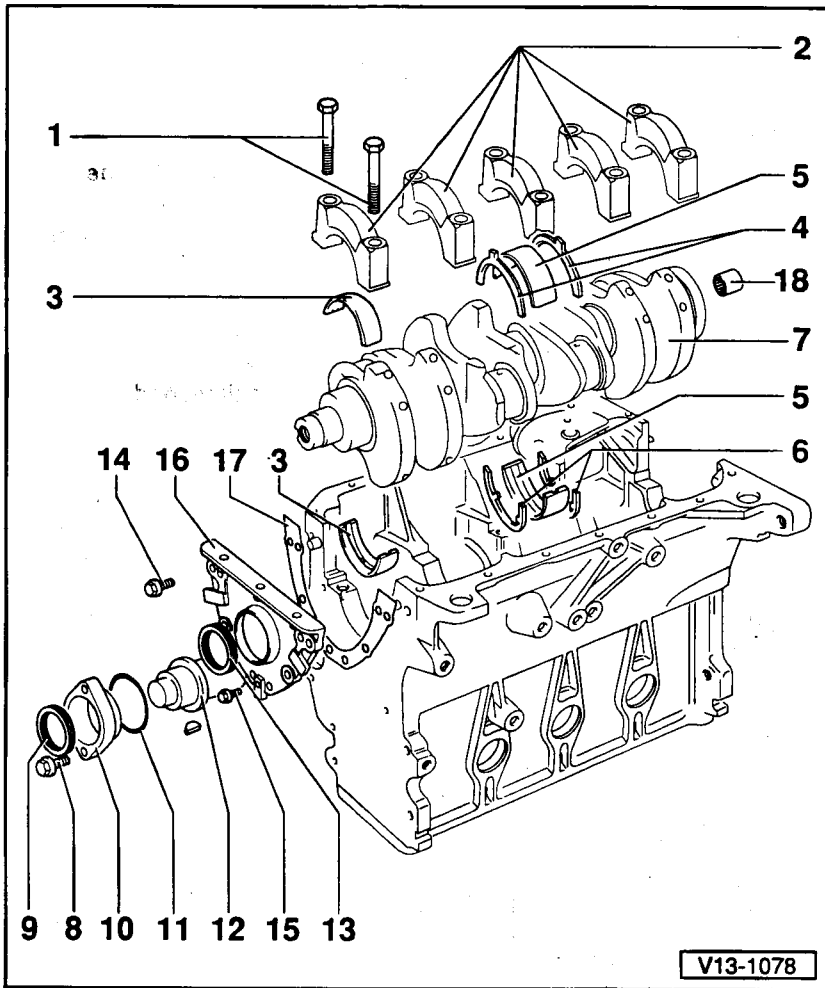

Dismantling and assembling cylinder block, crankshaft and flywheel

1 - 65 Nm

2 - Bearing cap

- ♦ Bearing cap 1: pulley end
- ♦ Bearing cap 3: with recesses for thrust washer
- ♦ Retaining lugs of bearing shells must be above one another

3 - Bearing shells 1, 2, 4 and 5

- ♦ For bearing cap without lubrication groove
- ♦ For cylinder block with lubrication groove
- ♦ Do not interchange used bearing shells

13-17

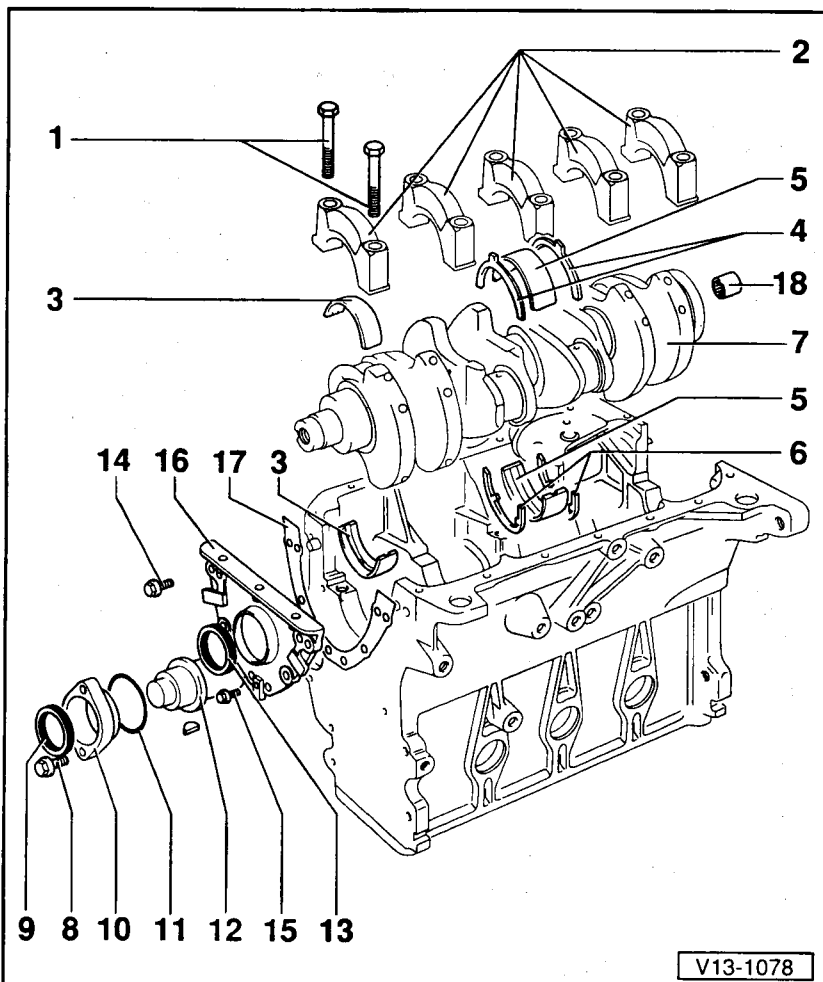

4 - Thrust washer

- ♦ For bearing cap 3
- ♦ Note fixing arrangement

5 - Bearing cap 3

- ♦ For bearing cap without lubrication groove
- ♦ For cylinder block with lubrication groove

6 - Thrust washer

- ♦ For cylinder block, bearing 3

7 - Crankshaft

- ♦ Axial play when new: 0.07...0.17 mm
Wear limit: 0.37 mm
- ♦ Measure radial play with plastigage
New: 0.03...0.08 mm
Wear limit: 0.17 mm
- ♦ Do not rotate crankshaft when measuring radial play
- ♦ Crankshaft dimensions
⇒ Page 13-27

13-18

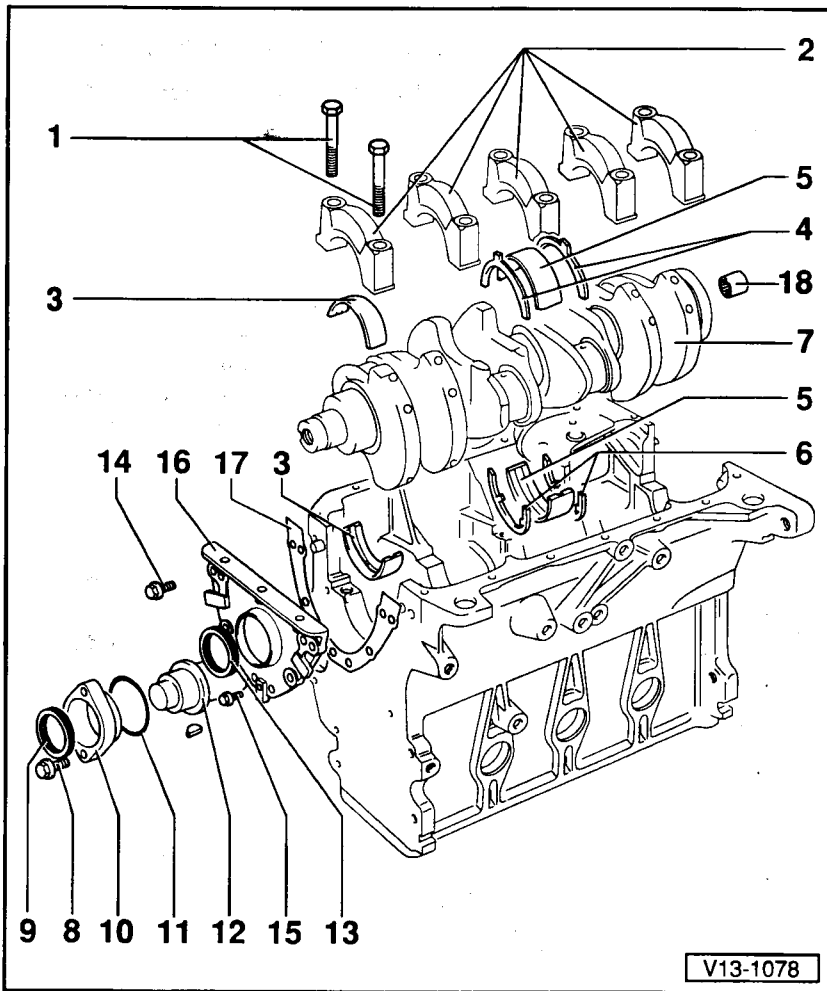

- 8 - 25 Nm
- 9 - Oil seal
 - ♦ Remove sealing flange to remove
 - ♦ Install with 10-203
 - ♦ Lightly oil sealing lip of oil seal
- 10 - Sealing flange intermediate shaft
- 11 - Sealing ring
 - ♦ Renew if damaged
- 12 - Intermediate shaft
- 13 - Oil seal
 - ♦ Renewing ⇒ Page 13-25
- 14 - 25 Nm
- 15 - 10 Nm
- 16 - Front sealing flange

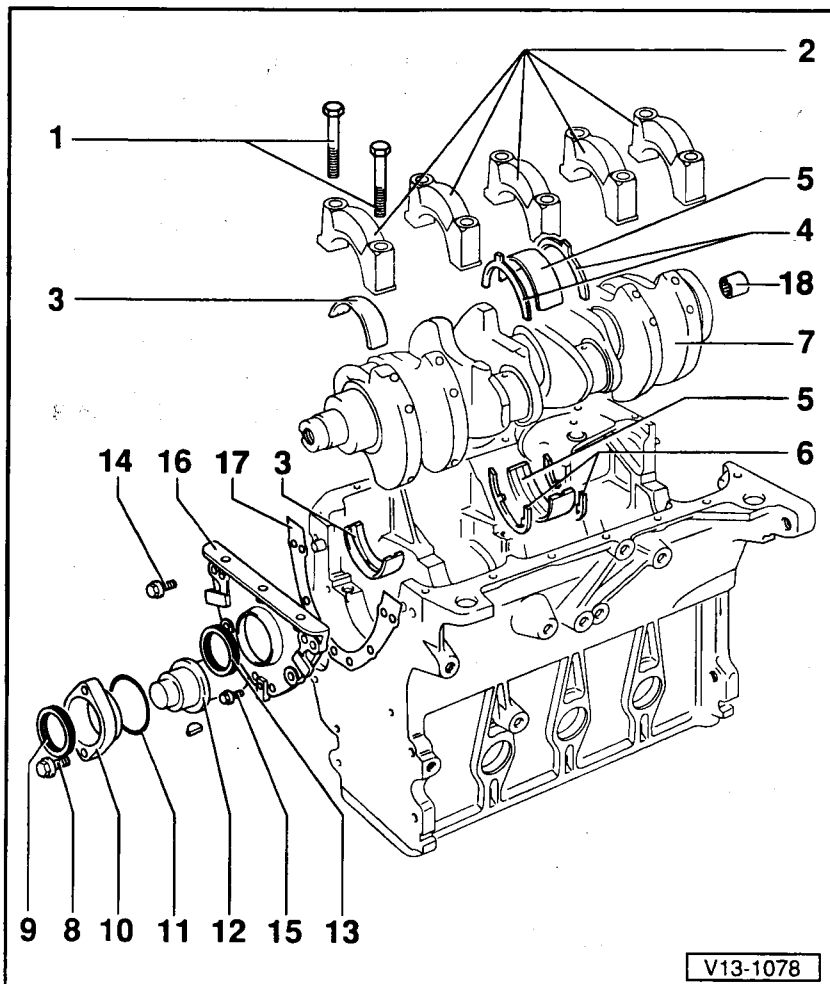

- 17 - Gasket
 - ♦ Renew
- 18 - Needle roller bearing
 - ♦ Removing ⇒ Fig. 1
 - ♦ Installing ⇒ Fig. 2
 - ♦ Insertion depth ⇒ Fig. 3
 - ♦ Coat with MoS₂ grease

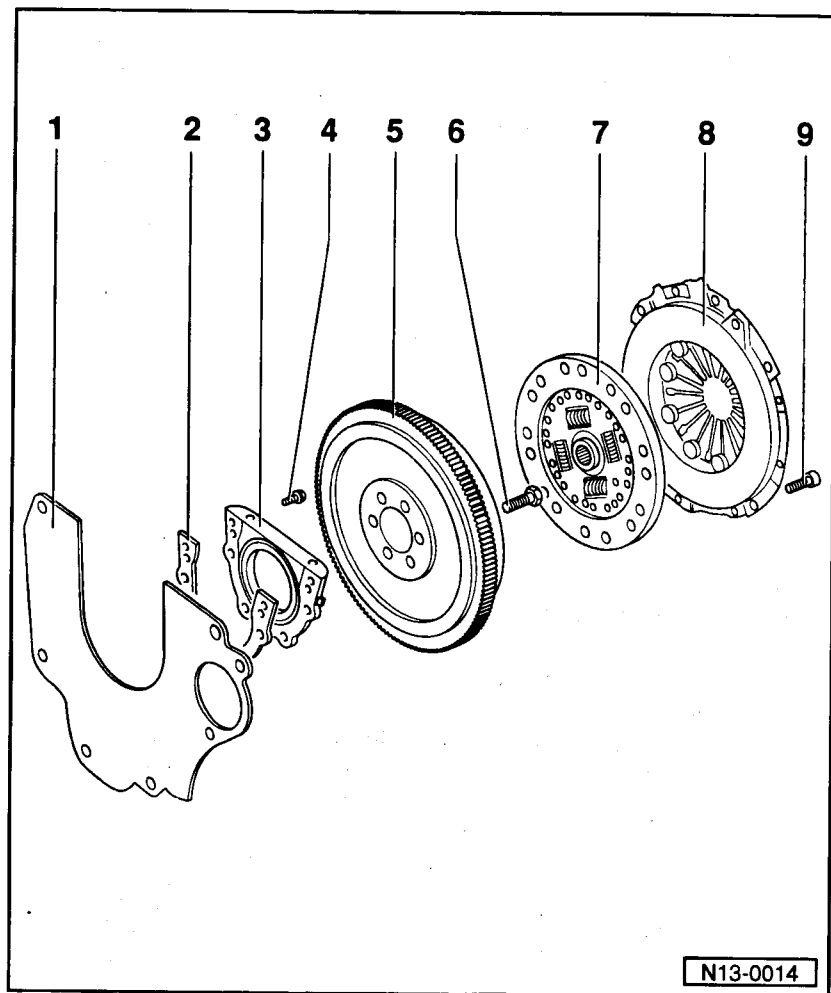

- 1 - Intermediate plate**
 - ♦ Must sit on dowel sleeves
 - ♦ Do not damage or bend when installing
- 2 - Gasket**
 - ♦ Renew
- 3 - Seal flange with oil seal**
 - ♦ Only renew complete
- 4 - 10 Nm**
- 5 - Flywheel**
 - ♦ Removing and installing
⇒ Fig. 4
- 6 - 60 Nm + ¼ turn (90°) further**
 - ♦ Renew
- 7 - Clutch plate**
 - ♦ Centralise with 3176
 - ♦ To remove and install counter-hold flywheel with 10-201

N13-0014

13-21

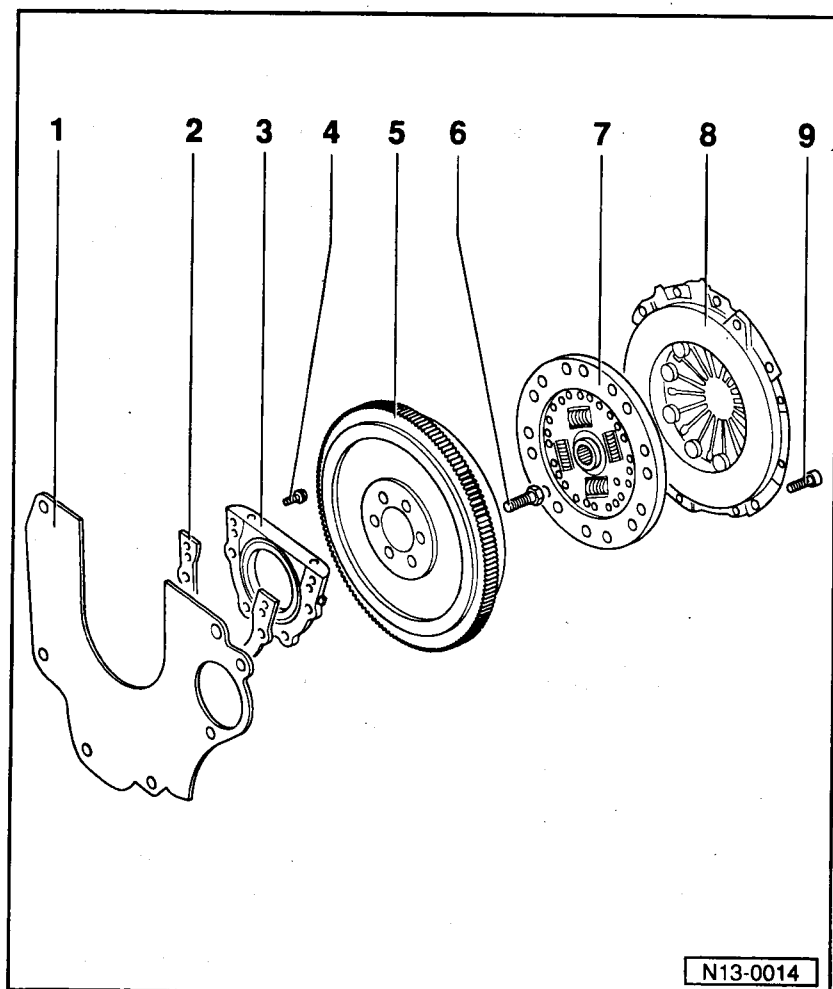

- 8 - Pressure plate**
 - ♦ Mark fitting position
- 9 - 25 Nm**
 - ♦ Loosen and tighten diagonally and in stages

N13-0014

13-22

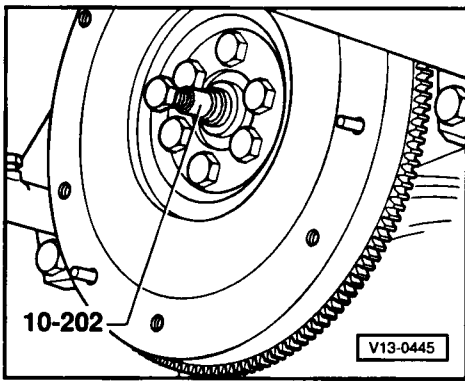

▲ Fig. 1 Removing needle roller bearing

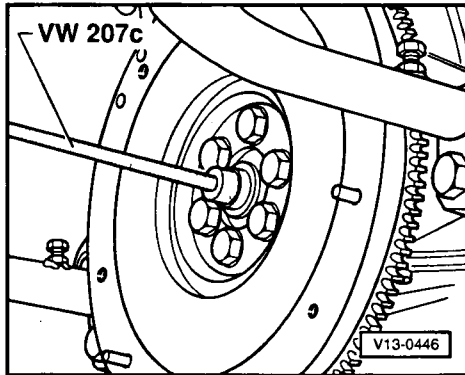

▲ Fig. 2 Installing needle roller bearing

With VW 207c or 3176

Lettering on end of needle roller bearing must be readable when installed.

————— 13-23 —————

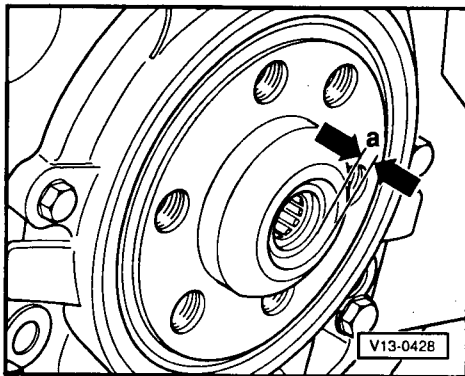

▲ Fig. 3 Insertion depth of needle roller bearing

a = 1.5 mm

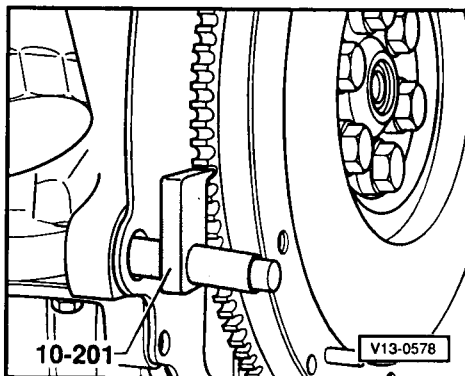

▲ Fig. 4 Removing and installing flywheel

Reverse counter-hold tool 10-201 when installing

————— 13-24 —————

Replacing crankshaft oil seal - pulley end

Removing

- Remove toothed belt ⇒ Page 13-13.
- Remove crankshaft sprocket. To do this, lock sprocket with counter hold tool 3099.
- ◀ - To guide the oil seal extractor, screw cylinder bolt from 3083 into crankshaft onto stop.
- Unscrew inner part of oil seal extractor 2085 two turns (about 3 mm) out of outer part and lock with knurled screw.
- ◀ - Oil threaded head of oil seal extractor and forcibly screw as far as possible into the oil seal.
- Loosen knurled screw and screw the inner part against the crankshaft until the oil seal has been pulled out.

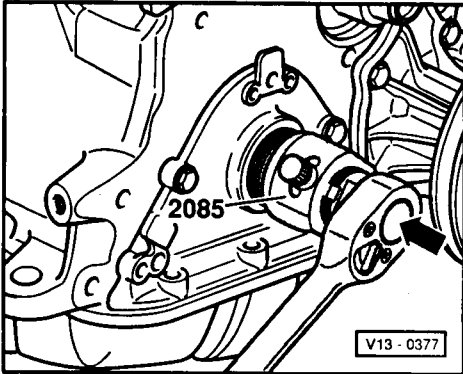
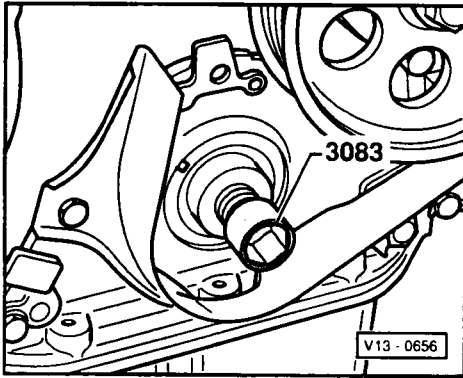

13-25

Installing

- Lightly oil the sealing lip of the oil seal.
- ◀ - Place guide sleeve from 3083 onto the crankshaft journal.
- Slide oil seal over guide sleeve.
- ◀ - Press oil seal in onto stop with press sleeve from 3083.
- Install toothed belt ⇒ Page 13-13.

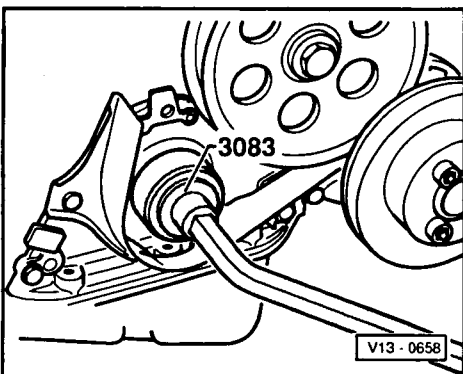
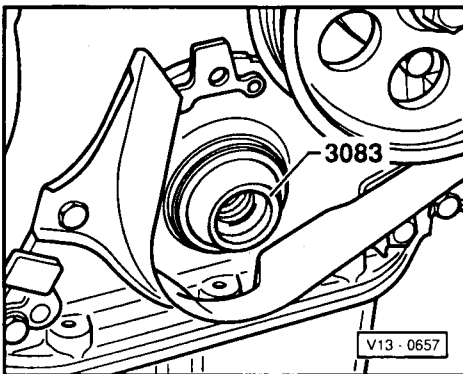

13-26

Crankshaft dimensions

(Dimensions in mm)

Honing dimension	Crankshaft main bearing journal Ø	Connecting rod bearing journal Ø
Original size	-0.022	-0.022
	54.00	47.80
1st undersize	-0.042	-0.042
	53.75	47.55
2nd undersize	-0.022	-0.022
	53.50	47.30
3rd undersize	-0.042	-0.042
	53.25	47.05

13-27

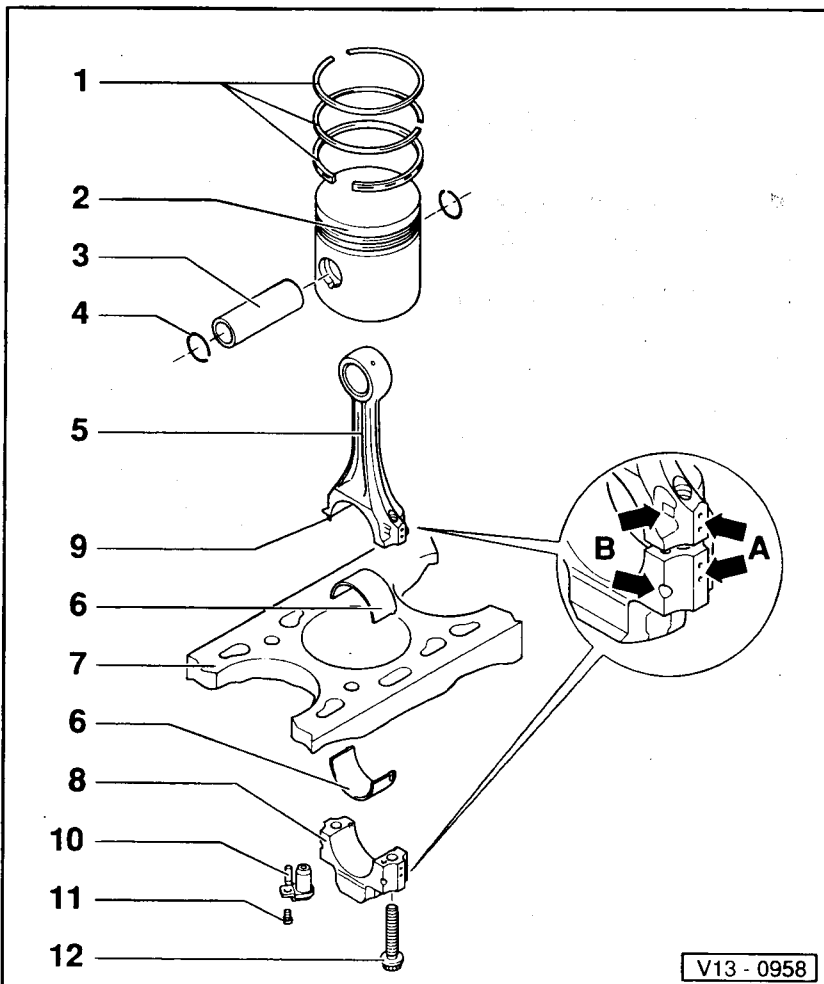

V13 - 0958

Dismantling and assembling pistons and conrods

1 - Piston rings

- ♦ Offset gaps 120°
- ♦ Remove and install with piston ring pliers
- ♦ Marking "TOP" towards the piston crown
- ♦ Checking ring gap ⇒ Fig. 1
- ♦ Checking side clearance ⇒ Fig. 2

2 - Piston

- ♦ Mark fitting position and cylinder number
- ♦ Arrow on piston crown points to pulley end
- ♦ With recess for oil spray jet
- ♦ Install with piston ring clamp
- ♦ Replace piston if skirt is cracked

13-28

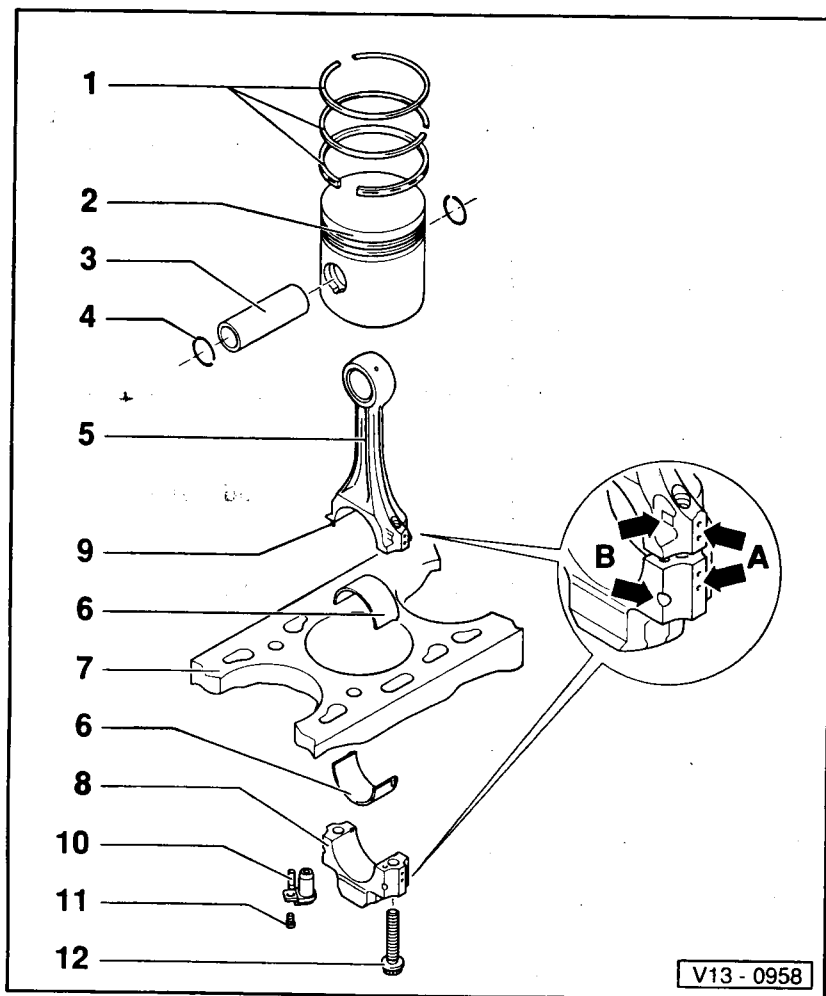

- Checking piston position at TDC
⇒ Page 13-34
- Piston pin drilling \varnothing :
Engine codes
028.B, ADG 24 mm
ADE 26 mm

3 - Piston pin

- If tight, heat piston to approx. 60 °C
- Use VW 222a to remove and install
- Piston pin \varnothing :
Engine codes
028.B, ADG 24 mm
ADE 26 mm

4 - Circlip

5 - Conrod

- Renew in sets only
- Mark with cylinder number -A-
- Fitting position:
marks -B- face towards pulley end
- Length
Engine codes
028.B, ADG 150 mm
ADE 144 mm

13-29

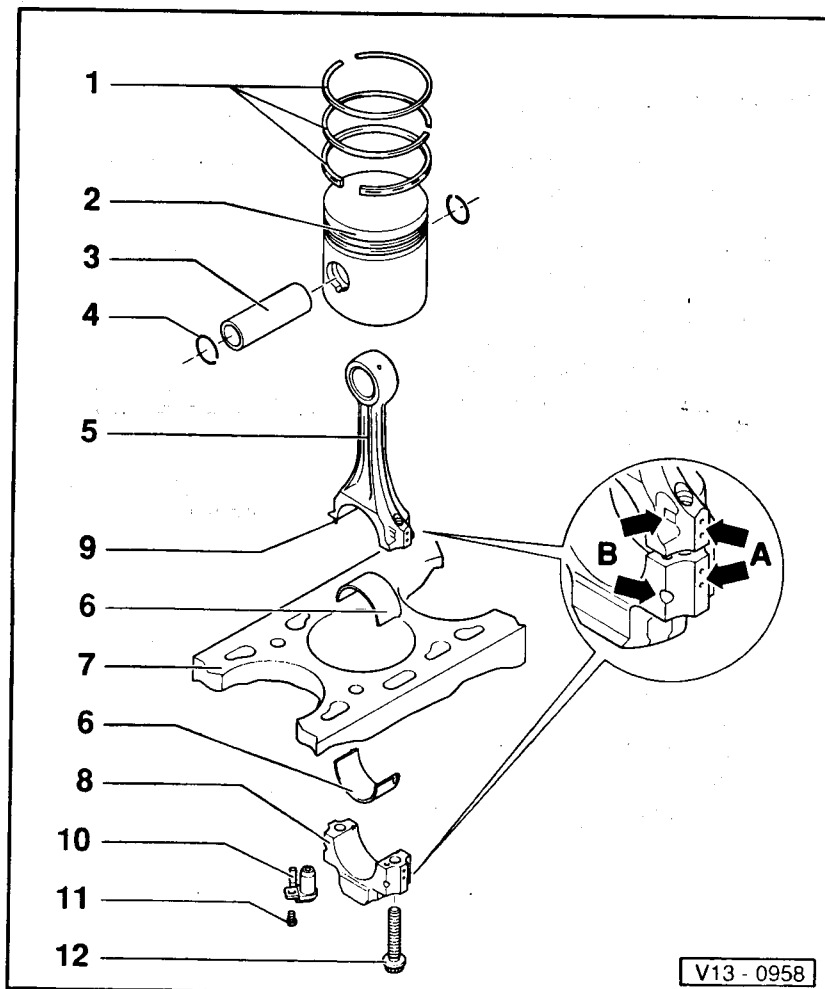

6 - Bearing shell

- Note fitting position
- Do not interchange used bearing shells
- Make sure retaining lugs are firmly seated
- Axial play:
Wear limit 0.37 mm
- Measure radial play with plastigage:
Wear limit: 0.08 mm
Do not rotate crankshaft when measuring radial play
- Width:
Engine code
028.B, ADG 19 mm
ADE 20 mm

7 - Cylinder block

- Checking cylinder bores
⇒ Fig. 3
- Piston and cylinder dimensions
⇒ Page 13-35

8 - Conrod cap

- Installation position:
markings -B- face towards pulley end

13-30

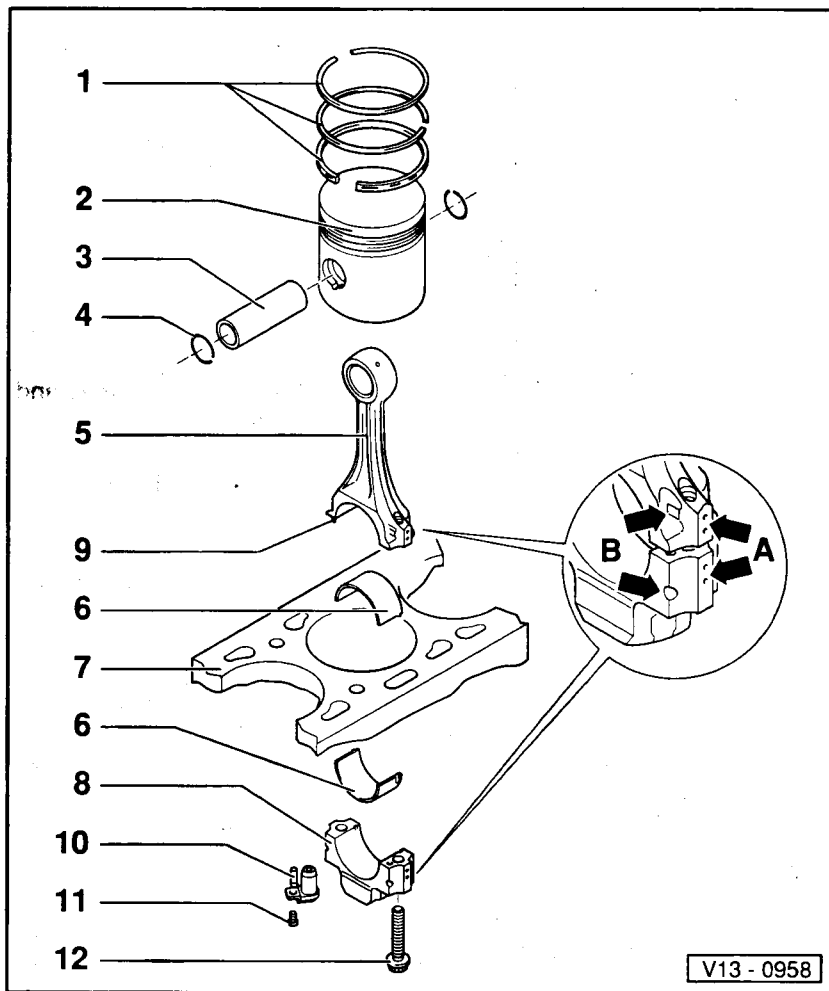

- 9 - Fitted pin
 - ♦ Fitted pin must sit tightly in the conrod and not in the cap
- 10 - Oil spray jet
 - ♦ For piston cooling
- 11 - 10 Nm
 - ♦ Install with AMV 188 100 02
- 12 - Conrod bolt, 30 Nm + ¼ turn (90°) turn further
 - ♦ Renew
 - ♦ Oil thread and head contact surface
 - ♦ Use old bolts when measuring radial clearance

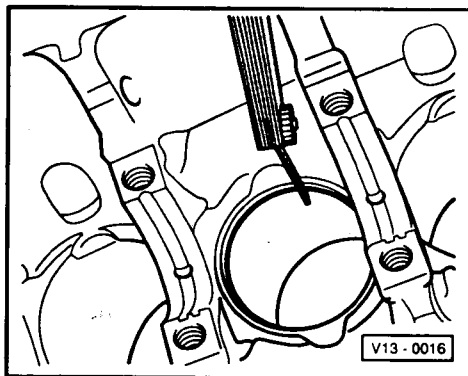

◀ Fig. 1 Piston ring - Checking ring gap

- Press ring squarely from above down to bottom end of cylinder about 15 mm from bottom edge.

Piston Ring (Dims. in mm)	Ring gap new	Wear limit
Compression ring, upper	0.20...0.40	1.20
Compression ring, lower	0.20...0.40	0.60
Oil scraper ring	0.25...0.50	1.20

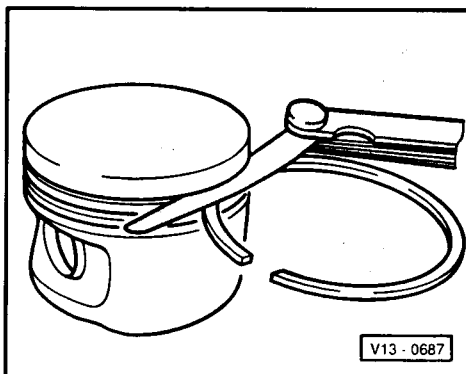

◀ Fig. 2 Piston rings - Checking side clearance

Clean the ring groove before checking.

Piston Ring (Dims. in mm)	Side clearance new	Wear limit
Compression ring, upper	0.09...0.12	0.25
Compression ring, lower	0.05...0.08	0.25
Oil scraper ring	0.03...0.06	0.15

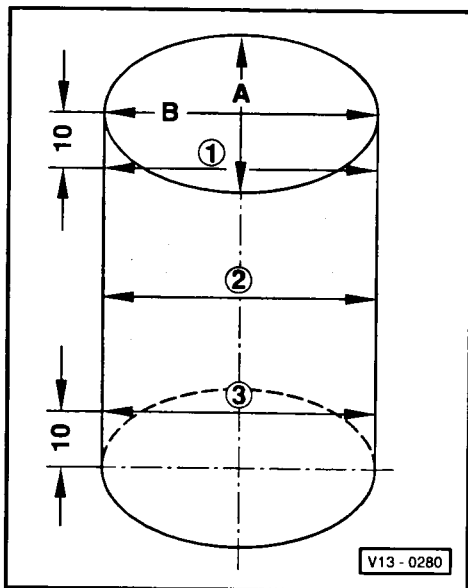

◀ Fig. 3 Checking cylinder bores

- Measure bores at 3 locations in both directions, -A- across the engine and -B- in line with crankshaft.

Deviation from nominal dimension
max. 0.10 mm.

Piston and cylinder dimensions ⇒ Page 13-35.

Note:

- Use internal dial gauge 50...100 mm.
- Measurement must not be done when the cylinder block is mounted on repair stand with adapter VW 540, as this can cause incorrect measurements.

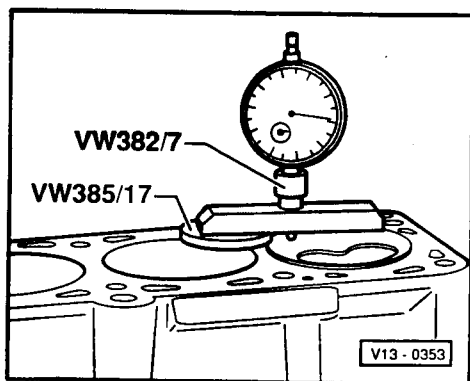

Checking piston at TDC

- ◀ The piston projection at TDC must be measured when fitting new pistons or short engines. Depending upon the piston projection, the appropriate cylinder head gasket is installed according to the following table:

Piston Projection	Identification (Number of notches/holes)
0.66 mm...0.86 mm	1
0.87 mm...0.90 mm	2
0.91 mm...1.02 mm	3

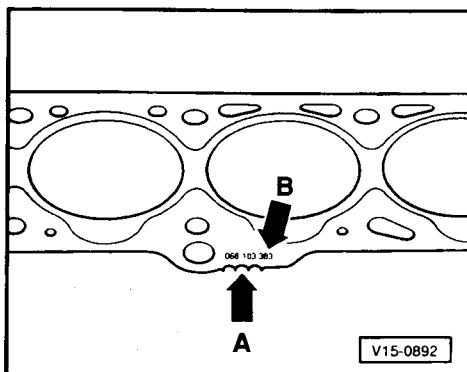

◀ Identification of cylinder head gasket

- No. of notches/holes - arrow A
- Spare part no. - arrow B (⇒ spare parts catalogue)

Note

If differing dimensions are obtained when measuring the piston projection, the largest dimension must be used for selecting the correct gasket.

Piston and cylinder dimensions

Honing Size		Piston Ø	Cylinder bores Ø
Basic size	mm	79.48	79.51
1st oversize	mm	79.73	79.76
2nd oversize	mm	79.98	80.01

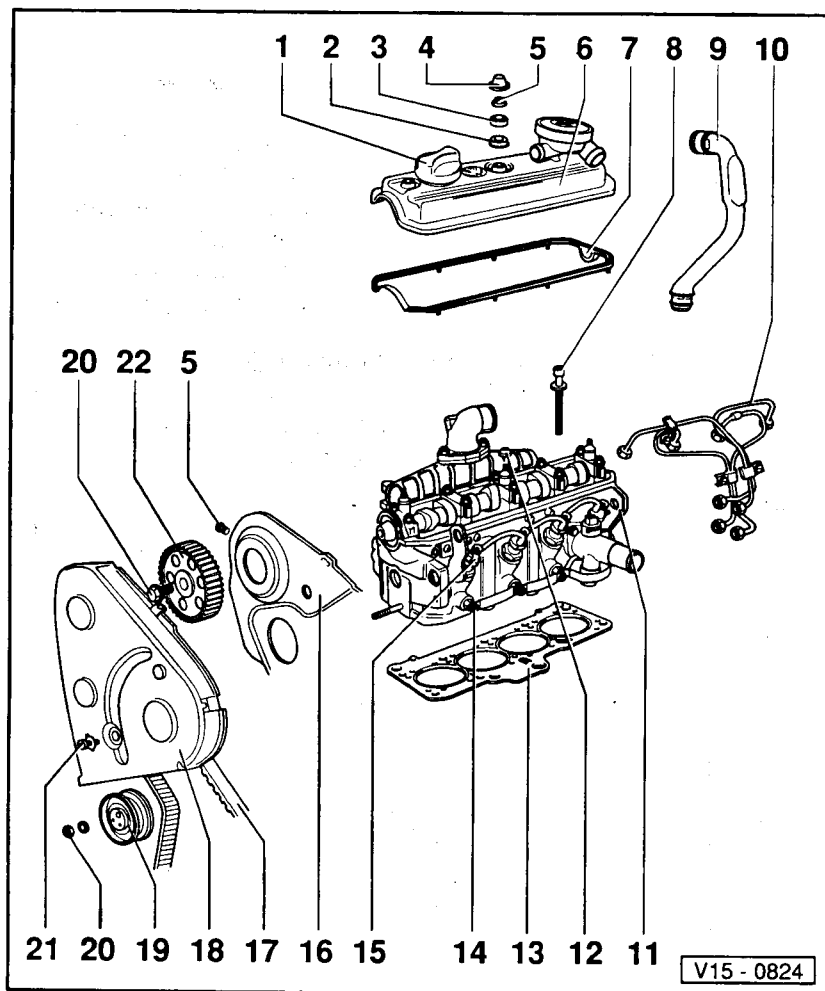

Removing and installing cylinder head

Checking compression pressures
 ⇒ Page 15-9

Note:

- ◆ The cylinder head can be removed and installed with engine in situ
- ◆ If an exchange cylinder head with camshaft is installed, the contact surfaces between the bucket tappets and the cam face must be lubricated after installing the head.
- ◆ The plastic caps supplied for protecting the open valves must not be removed until immediately prior to fitting the cylinder head.
- ◆ When replacing the cylinder head, fill complete system with fresh coolant.

15-1

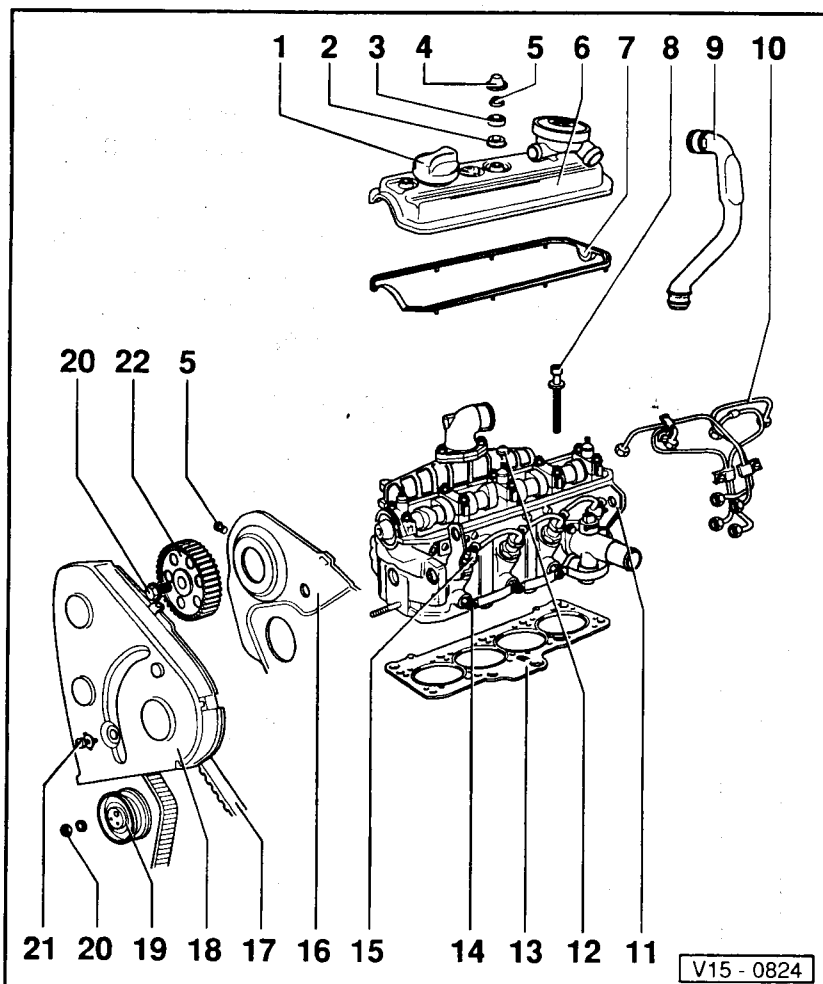

- 1 - Oil filler cap
 - ◆ Renew seal if damaged
- 2 - Upper sealing washer
 - ◆ Renew if damaged
- 3 - Dished washer
- 4 - Cover cap
- 5 - 10 Nm
- 6 - Cylinder head cover
- 7 - Cylinder head cover gasket
 - ◆ Renew if damaged
 - ◆ Insert lugs in holes in cylinder head
- 8 - Cylinder head bolts
 - ◆ Renew
 - ◆ Note installation instructions and sequence when loosening and tightening ⇒ Page 15-7.

15-2

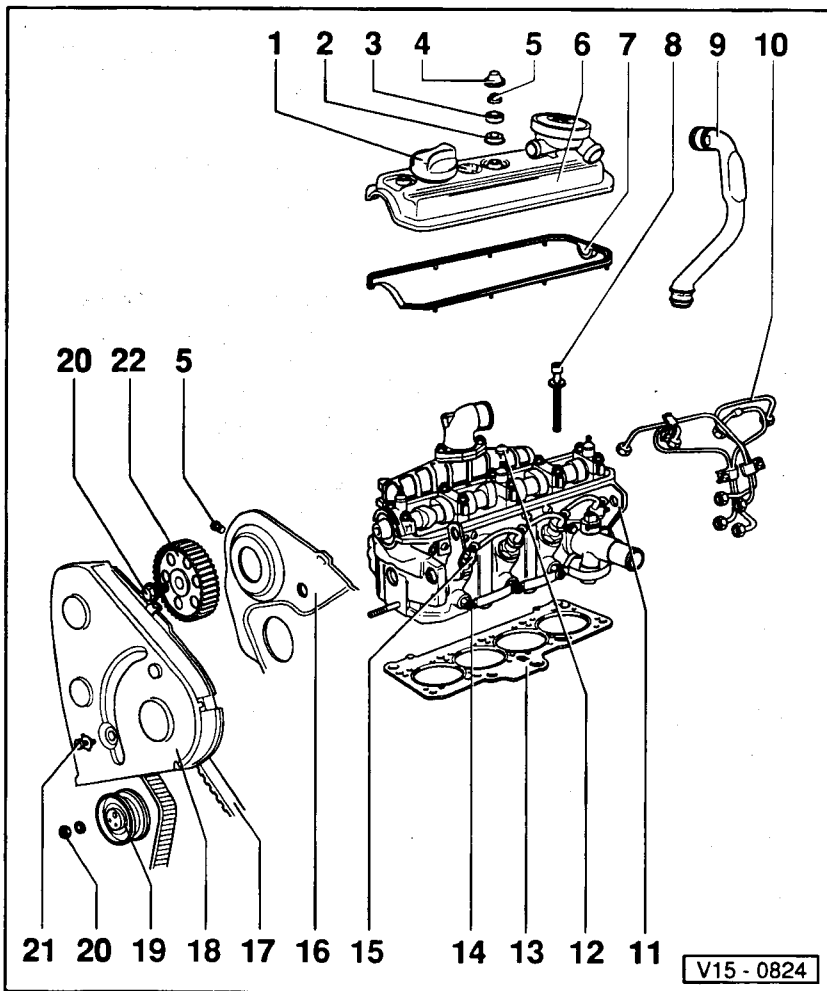

9 - Crankcase breather

10 - Injector pipes

- ◆ Tighten to 25 Nm
- ◆ Remove and install with open ring spanner 3035
- ◆ Always remove pipe set complete
- ◆ Do not alter shape

11 - Cylinder head

- ◆ Checking for distortion ⇒ Fig. 1
- ◆ Servicing valve gear ⇒ Page 15-11
- ◆ Installing ⇒ Page 15-7
- ◆ After replacing, fill complete system with new coolant

12 - Lower cone seal

- ◆ Renew if damaged

13 - Cylinder head gasket

- ◆ Renew
- ◆ Note markings ⇒ Fig. 2
- ◆ After replacing, fill the entire system with new coolant

15-3

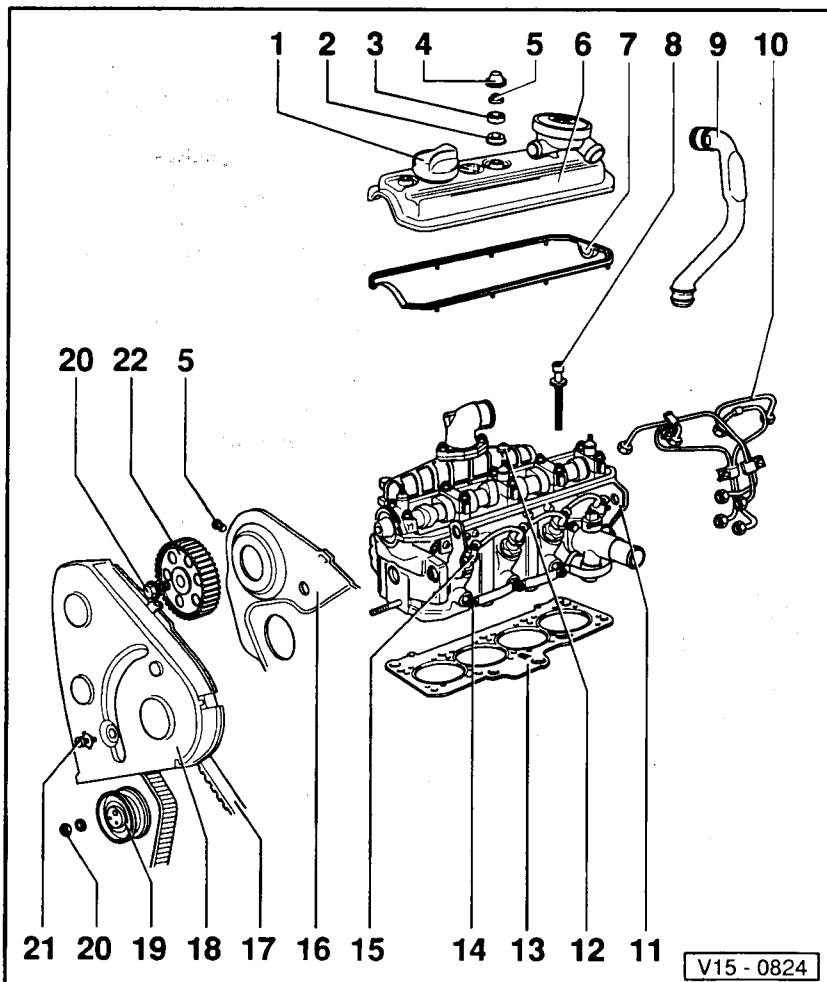

14 - Glow plug

- ◆ Tighten to 25 Nm
- ◆ Checking ⇒ Page 28-3

15 - Injector

- ◆ Tighten to 70 Nm
- ◆ Removing and installing ⇒ Page 23-22
- ◆ Servicing ⇒ Page 23-23

16 - Rear toothed belt guard

- ◆ To remove cylinder head, remove securing bolt on head and push guard back slightly

17 - Toothed belt

- ◆ Before removing mark direction of rotation
- ◆ Check for wear
- ◆ Do not kink
- ◆ Removing and installing ⇒ Page 13-13
- ◆ Adjusting tension ⇒ Page 13-15

15-4

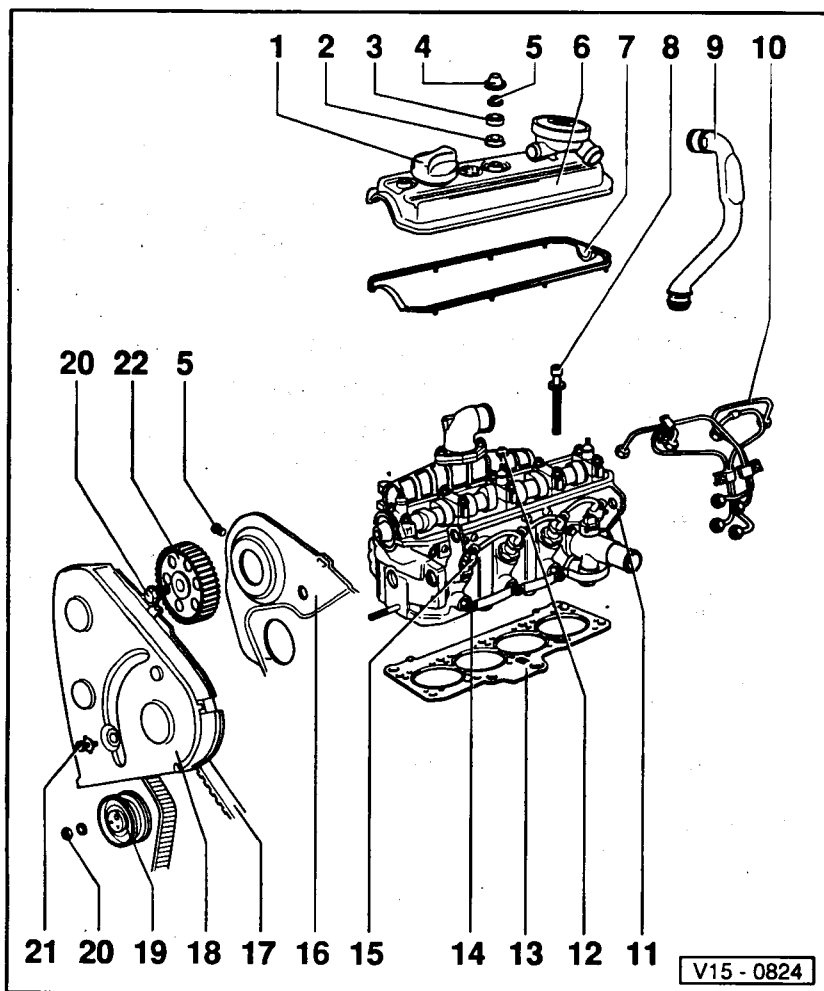

- 18 - Upper toothed belt guard
- 19 - Tensioning roller
 - ◆ Adjusting toothed belt tension
⇒ Page 13-15
- 20 - 45 Nm
- 21 - Expanding clip
 - ◆ Loosen with coin
- 22 - Camshaft sprocket
 - ◆ To loosen from camshaft taper, insert drift through the opening in the toothed belt guard and tap with a hammer

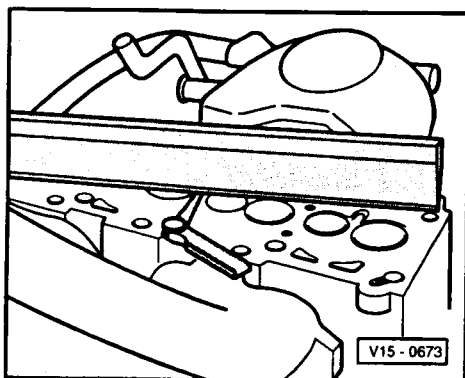

◀ Fig. 1 Checking the cylinder head for distortion

Maximum permissible distortion: 0.1 mm

Note:

Reworking of diesel cylinder heads is not permitted.

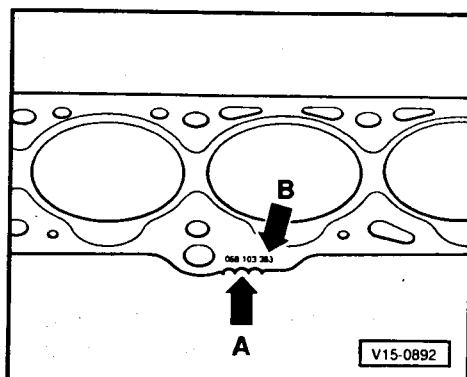

◀ Fig. 2 Cylinder head gasket identification

◆ Number of notches/holes - arrow A

◆ Part No. - arrow B (⇒ spare parts catalogue)

The thickness of the cylinder head gasket installed depends on the piston projection. When renewing the gasket, install a new gasket with identical markings.

Installing cylinder head

Note:

- ◆ Always renew cylinder head bolts.
- ◆ In cases of repair carefully remove remains of gasket from cylinder head and cylinder block. When doing this ensure that no long scoring or scratches are caused. When using emery paper the grade must not be less than 100.
- ◆ Carefully remove emery paper and cleaning residues.
- ◆ Only unpack cylinder head gasket immediately prior to fitting.
- ◆ Handle gasket with great care. Damage to the silicone coating or in the area of the beading will lead to leaks.

- Before fitting cylinder head set crankshaft to TDC.

- Turn crankshaft opposite to engine direction of rotation, until all pistons are about the same distance below TDC.

- Place cylinder head gasket on dowel sleeves.

◀ - To centralise, screw guide pins from 3070 into the outer threaded holes on the intake side of the cylinder block.

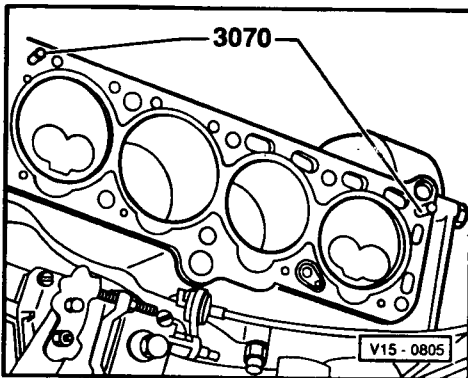

15-7

- Fit cylinder head, insert the remaining 8 cylinder head bolts and tighten by hand.

- Unscrew the guide pins from the bolt holes using the removal tool from 3070 and insert cylinder head bolts.

◀ - Tighten all bolts in 4 stages in the sequence shown (engine cold).

- 1. Pre tighten with torque wrench
Stage I = 40 Nm
Stage II = 60 Nm

- 2. Turn further with normal spanner
Stage III = ¼ turn (90°)
Stage IV = ¼ turn (90°)

Note:

◆ Since metal gaskets have been fitted (11.93) it is no longer necessary to retighten the cylinder head bolts by ¼ turn (90°) with the engine warm.

◆ Loosening cylinder head bolts: Reverse sequence

- After tightening the cylinder head, rotate the camshaft sprocket so that the No. 1 cylinder cams face upwards at the same angle. Before installing the toothed belt set the crankshaft to TDC cylinder No. 1 by rotating in engine direction of rotation.

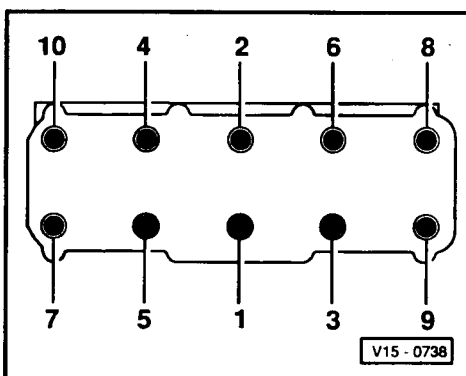

15-8

Checking compression pressures

- Minimum engine oil temperature 30° C
- Disconnect wire from the fuel shut-off valve on the injection pump and isolate it.
- Remove injector pipes with open ring spanner 3035.
- Unscrew all injectors and remove heat shields.
- ◀ - Screw in adapter V.A.G. 1323/2A in place of the injectors.
Place old heat shield between adapter and cylinder head.
- Screw compression pressure recorder V.A.G. 1381 into the adapter by hand.

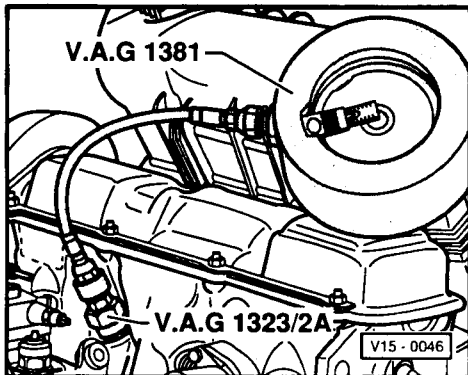

Note:

Using the compression recorder ⇒ operating instructions.

- Operate starter until no further pressure increase is indicated on the compression recorder.

15-9

Compression pressure for V.A.G. 1381 and VW 1323

(Gauge pressure)

Specification	34.0 bar
Wear limit	26.0 bar
Max. permissible pressure difference	5.0 bar

Note:

- ◆ Always place heat shields between cylinder head and the injectors.

- ◀ ◆ Fitting position for heat shield:
Arrow points to cylinder head

Tightening torques:

Injector pipes	25 Nm
Injectors	70 Nm

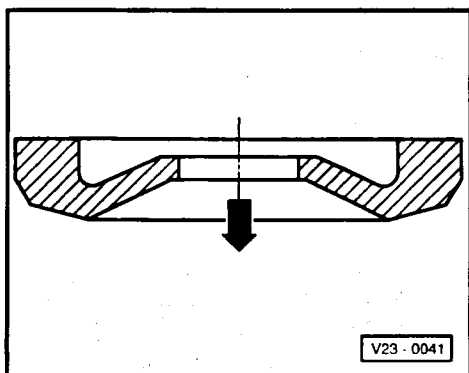

15-10

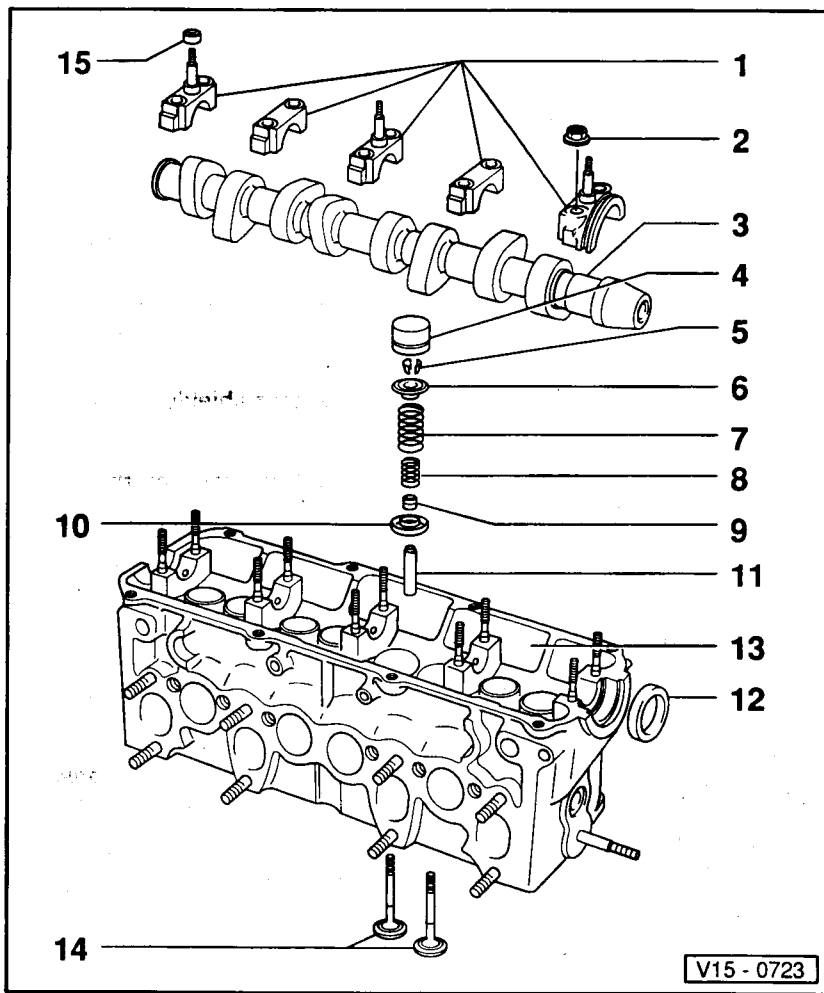

Servicing valve gear

Note:

Cylinder heads which have cracks between the valve seats can be used further without reducing in-service life, provided the cracks are small, not more than 0.5 mm wide.

1 - Bearing cap

- ◆ Installation position ⇒ Fig. 2
- ◆ Installation sequence ⇒ Page 15-21, Removing and installing camshaft

2 - 20 Nm

15-11

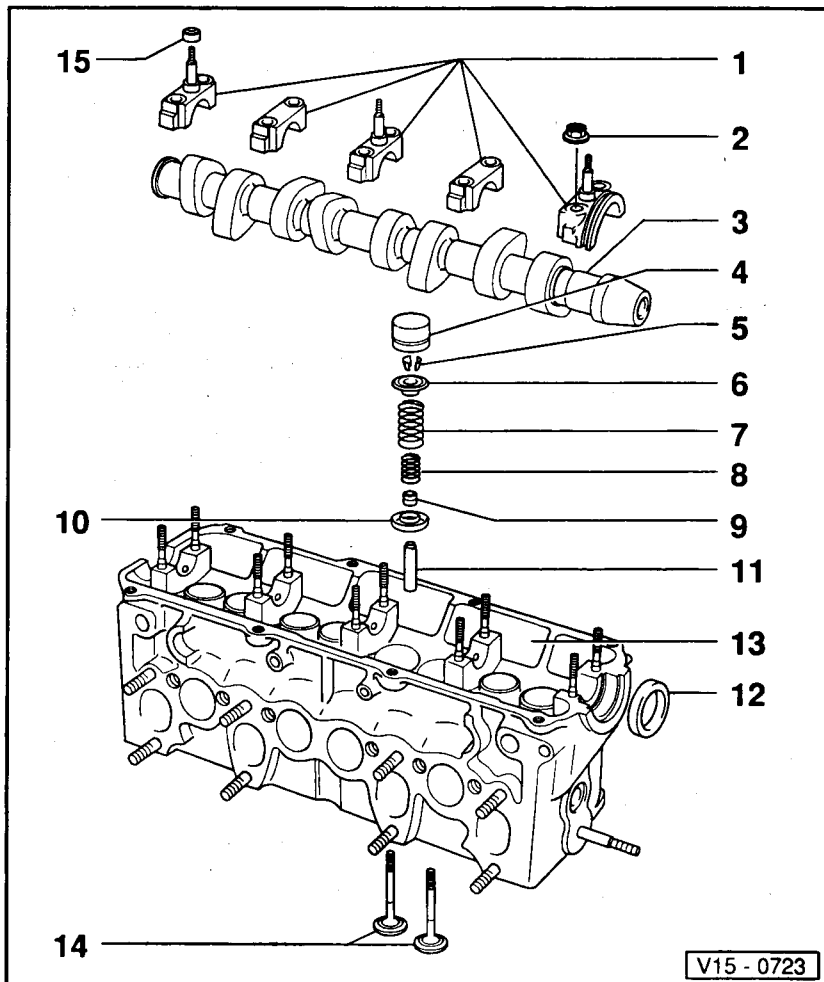

3 - Camshaft

- ◆ Checking axial play ⇒ Fig. 1
- ◆ Removing and installing ⇒ Page 15-21
- ◆ Measure radial clearance with plastigage
Wear limit: 0.11 mm
- ◆ Run-out: max. 0.01 mm
- ◆ Valve timing at 1 mm valve opening:

Inlet opens	6° after TDC
Inlet closes	20° after BDC
Exhaust opens	25.5° before BDC
Exhaust closes	6.5° before TDC

4 - Bucket tappets

- ◆ With hydraulic valve clearance compensation
- ◆ After removing, place contact surfaces downwards
- ◆ Do not interchange
- ◆ Checking ⇒ Page 15-22
- ◆ Oil contact surfaces
- ◆ Before installing, check camshaft axial play ⇒ Fig. 1

15-12

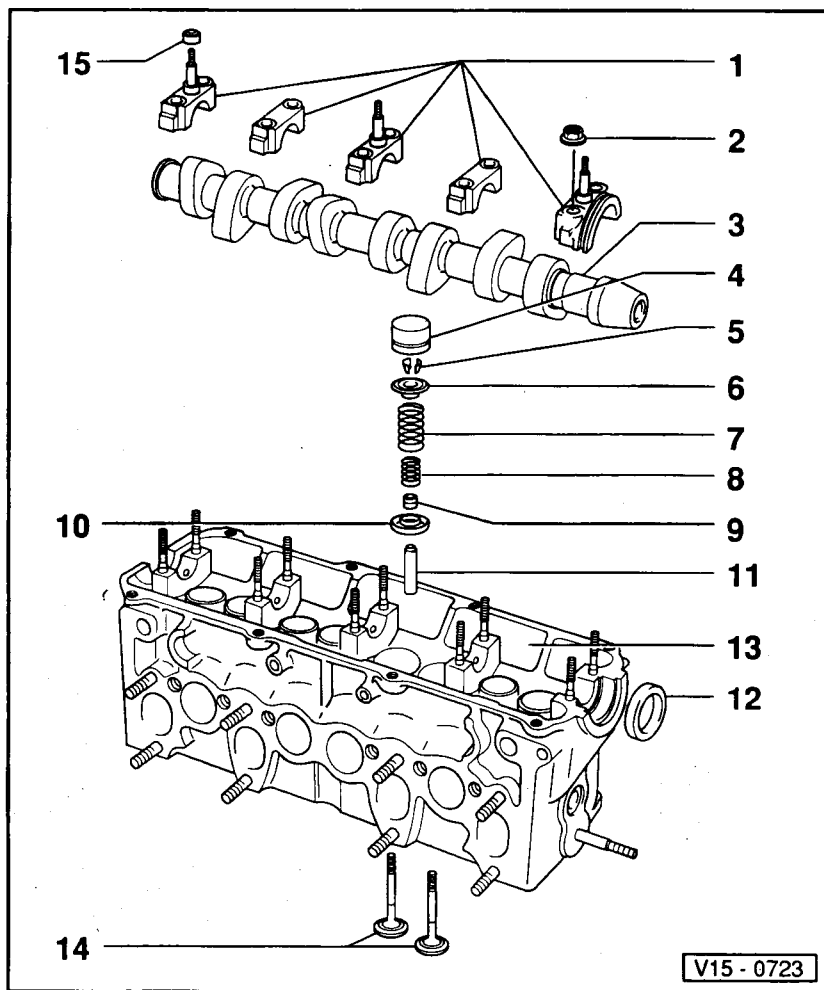

- 5 - Valve cotters
 - ◆ Use 2037 to remove and install
 - ◆ If cotter is jammed, loosen by lightly tapping assembly tool spindle with hammer
- 6 - Upper valve spring seat
- 7 - Outer valve spring
 - ◆ Remove and install with 2037
- 8 - Inner valve spring
 - ◆ Remove and install with 2037
- 9 - Valve stem seal
 - ◆ Renewing ⇒ Page 15-20
- 10 - Lower valve spring seat,
 - ◆ Remove and install with 3047A
- 11 - Valve guide
 - ◆ Checking ⇒ Page 15-19
 - ◆ Renewing ⇒ Page 15-19
 - ◆ Service version with collar

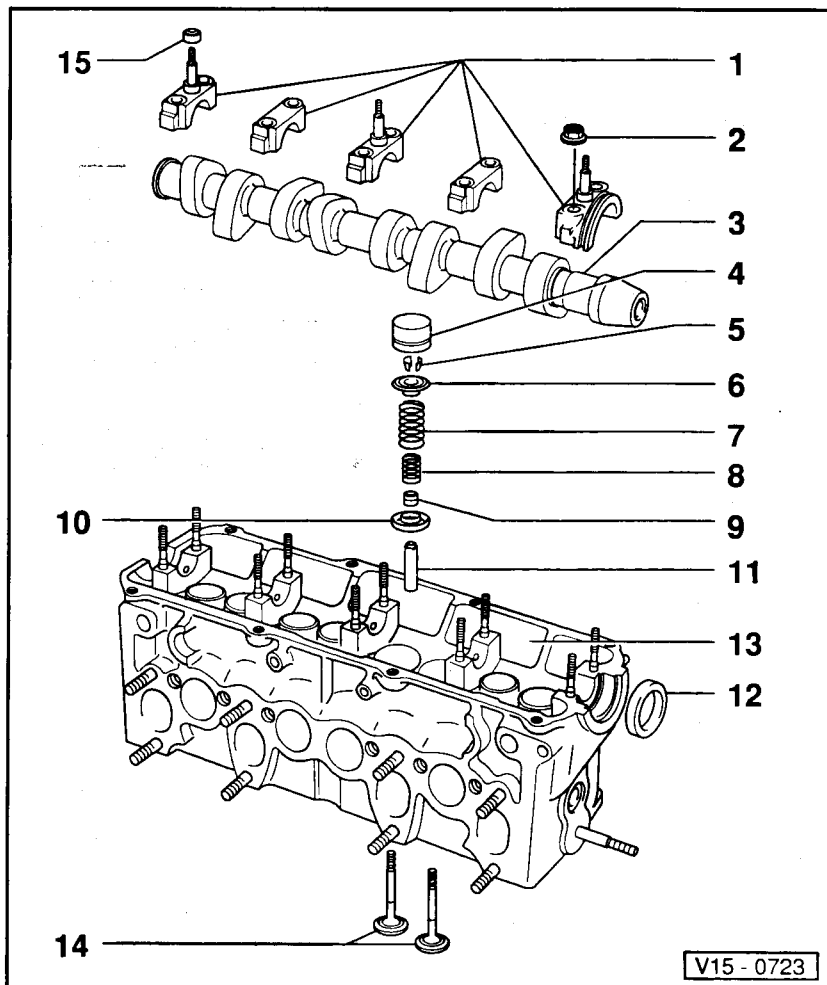

- 12 - Oil seal
 - ◆ To replace, remove bearing cap
 - ◆ Removing and installing toothed belt ⇒ Page 13-13
- 13 - Cylinder head
 - ◆ Reworking valve seats ⇒ Page 15-17
- 14 - Valves
 - ◆ Valve dimensions ⇒ Fig. 3
 - ◆ Reworking inlet valve ⇒ Fig. 4
- 15 - Lower sealing cone
 - ◆ Renew if damaged

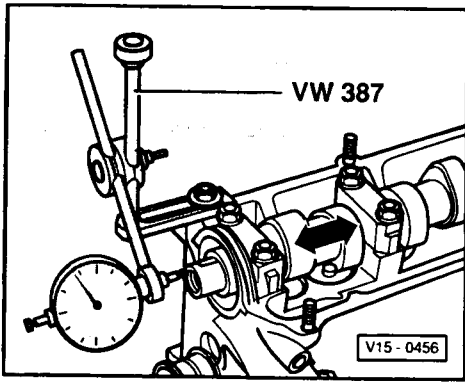

◀ Fig. 1 Checking camshaft axial play

Maximum permissible axial play: 0.15 mm

Measure with bucket tappets removed and first and last bearing caps fitted.

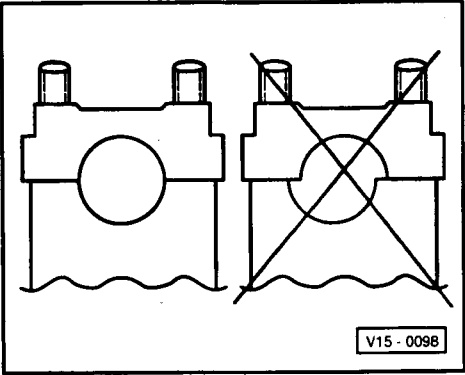

◀ Fig. 2 Fitting position of camshaft bearing cap

Note offset. Before installing the camshaft, fit bearing caps to determine correct fitting positions.

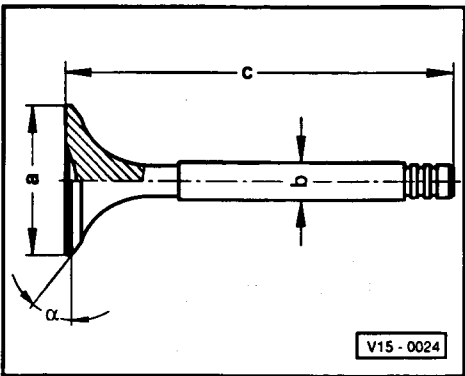

◀ Fig. 3 Valve dimensions

Dimensions		Inlet valve	Exhaust valve
Ø a	mm	36.00	31.00
Ø b	mm	7.97	7.95
c	mm	95.00	95.00
α	∠°	45	45

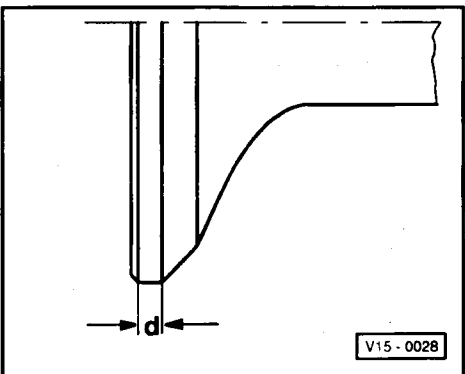

◀ Fig. 4 Reworking inlet valves

When reworking the valve dimension -d- must not be less than
 $d = 0.5 \text{ mm}$

Attention!
 Exhaust valves must not be reworked only grinding in is permitted.

Reworking valve seats

Checking valve guides ⇒ Page 15-19.

Note:

- ◆ When repairing engines with leaking valves, it is not sufficient to rework and renew the valve seats and valves. Particularly in the case of engines which have high operating hours, it is necessary to check the valve guides for wear.
- ◆ Rework the valve seats only enough to produce a perfect contact surface. Before reworking commences, calculate the maximum permissible reworking dimension. If this dimension is exceeded, the correct functioning of the hydraulic tappets can no longer be guaranteed and the cylinder head must be renewed.

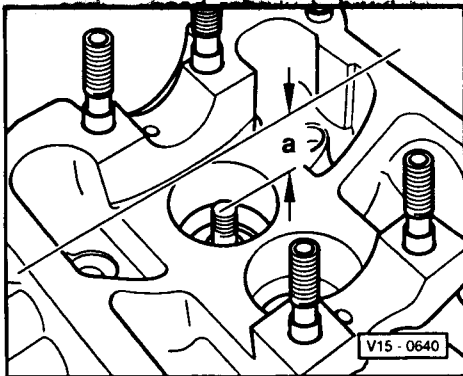

Calculating max. permissible reworking dimension

- Insert valve and press in hard against valve seat.

Note:

If the valve is to be renewed during the repair work, use a new valve for the measurement.

- ◀ - Measure the dimension -a- between the end of valve stem and the upper edge of the cylinder head.

15-17

- Calculate the maximum permissible reworking dimension from the measured value and the minimum dimension.

Minimum dimensions:

Inlet valve 35.8 mm
Exhaust valve 36.1 mm

Measured dimension minus minimum dimension
= max. permissible reworking dimension.

Example:

Measured dimension	36.5 mm
- Minimum dimension	35.8 mm
= max. permissible reworking dim.	0.7 mm

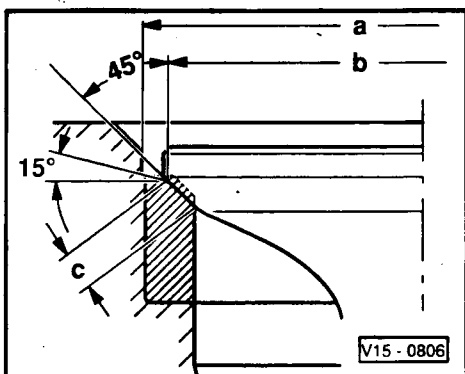

Reworking valve seats

Dimensions	Inlet valve seat	Exhaust valve seat
Ø a mm	37.20 ¹⁾	33.20 ¹⁾
Ø b mm	34.80	30.40
c mm	2.70	2.05
45°	Valve seat angle	
15°	Correction angle	

¹⁾ Max. outer diameter of the correction cutter

15-18

Checking valve guides

- Remove combustion residue with cleaning reamer.
- Insert new valve into guide. End of valve stem must be flush with the guide. Due to the difference in stem dimensions, ensure that only an inlet valve is used in the inlet guide and an exhaust valve in the exhaust guide.

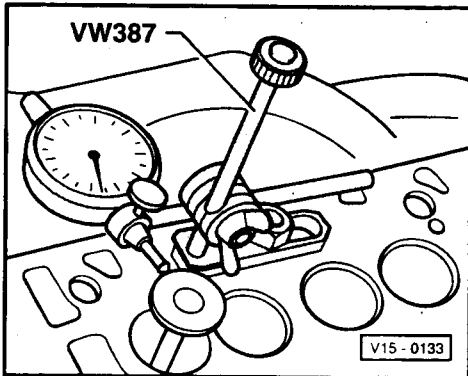

- ◀ - Determine rock.
Wear limit: 1.3 mm

Renewing valve guides

- Clean and check cylinder head. Cylinder heads whose valve seat inserts can no longer be refaced or cylinder heads which have already been reworked down to the minimum dimension are not suitable for renewing valve guides.
- Press out the worn valve guides using 10-206, from the camshaft side (valve guides with shoulder service version are pressed out from the combustion chamber side).
- Coat new guides with oil and, using 10-206, press in from the camshaft side, with cylinder head cold, until shoulder makes contact.

15-19

Note:

When the shoulder on guide makes contact with the cylinder head, the press-in pressure must not exceed 1.0 tonne, otherwise the shoulder may break off.

- Ream out the guides using hand reamer 10-215. using plenty of cutting fluid.
- Reworking valve seats ⇒ Page 15-17.

Renewing valve stem oil seals

(with cylinder head installed)

- Remove camshaft ⇒ Page 15-21.
- Remove the bucket tappets (do not interchange) and place with the contact surfaces downwards.
- Move the piston of the cylinder concerned to "Top Dead Centre" (TDC).

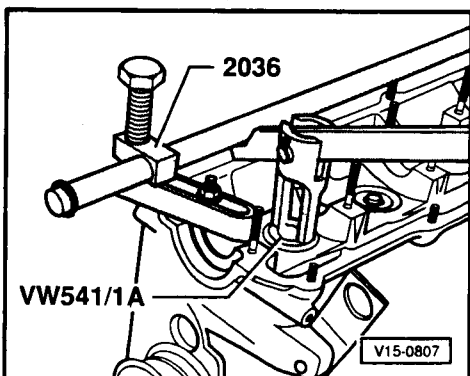

- ◀ - Remove valve springs using 2036 and VW 541/1A. The valves then rest on the piston crown.

15-20

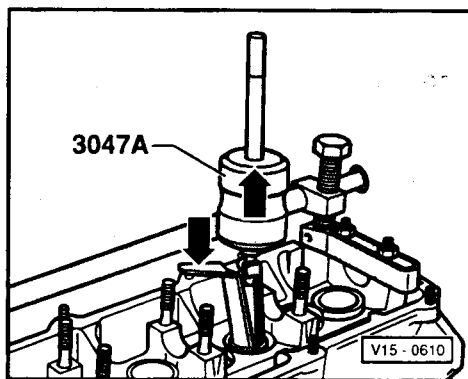

- ◀ - Pull off valve stem seal.

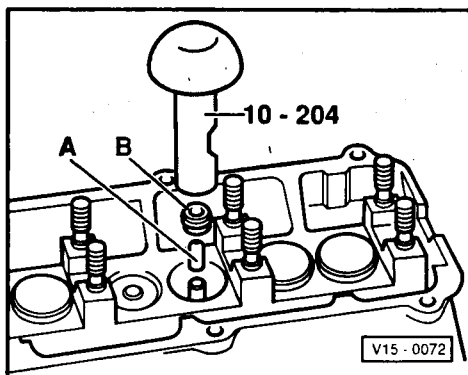

- ◀ - In order to prevent damage to the new valve stem seals, fit plastic sleeve -A- onto the valve stem.
- Oil the valve stem seal -B-, place it in the press-in tool 10-204 and push it down carefully onto the valve guide.

Removing and installing camshaft

Removing

- With cylinder head installed, rotate engine until No. 1 cylinder is at TDC.
- Removing and installing toothed belt ⇒ Page 13-13.

15-21

- First remove bearing caps 5, 1 and 3. Loosen bearing caps 2 and 4 alternately and diagonally.

Installing

- Cams for no. 1 cylinder must be pointing upwards
- Oil the contact surfaces.
- Install bearing caps 2 and 4, note the offset and tighten alternately and diagonally.
- Install bearing caps 5, 1 and 3.
- Fit bearing cap 5 by tapping lightly on the end of camshaft.

Checking hydraulic bucket tappets

Note:

- ◆ *Only renew tappets complete (cannot be adjusted or reworked).*
- ◆ *Irregular valve noises when starting engine are normal.*
- Start the engine and run until radiator fan has cut-in once.
- Increase engine speed to approx. 2500 rpm for 2 minutes.

If the hydraulic bucket tappets are still noisy, locate defective tappet as follows:

15-22

- Remove cylinder head cover.
- Rotate the crankshaft clockwise until the cam of the tappet to be checked is pointing upwards.
- Determine clearance between cam and bucket tappet.

If the clearance exceeds 0.1 mm, replace bucket tappet. If the clearance measured is less than 0.1 mm or no clearance is perceptible, proceed with check as follows:

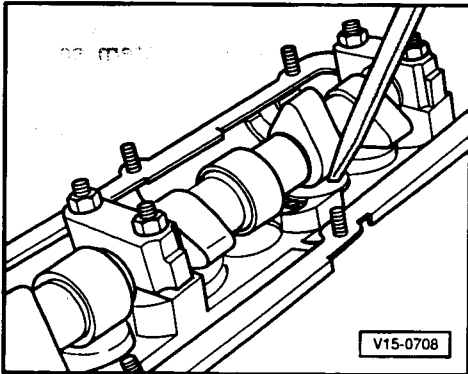

- ◀ - Press tappet down with a wooden or plastic wedge. If free travel in excess of 0.1 mm is felt before contacting the valve stem, renew the tappet.

Note:

After the installing new tappets, the engine must not be started for about 30 minutes. Hydraulic compensation elements must settle (valves can strike pistons).

Removing and installing parts of the lubrication system

Note:

If, when repairing an engine, a large quantity of swarf or fine metal particles are found in the engine oil caused e.g. by seizure of crankshaft and conrod bearings, the oil drillings must be very carefully cleaned and the oil cooler renewed to prevent subsequent damage.

Checking oil pressure ⇒ Page 17-7

Oil capacities:

Without oil filter change 4.0 l
With oil filter change 4.5 l

Engine oil specification

Turbo-Diesel:

Use only oils which conform to VW Standard 50500.

Normally aspirated Diesel:

Use only engine oils which conform to VW Standard 50000, 50101 or 50500 or multigrade oils according to API-CD.

17-1

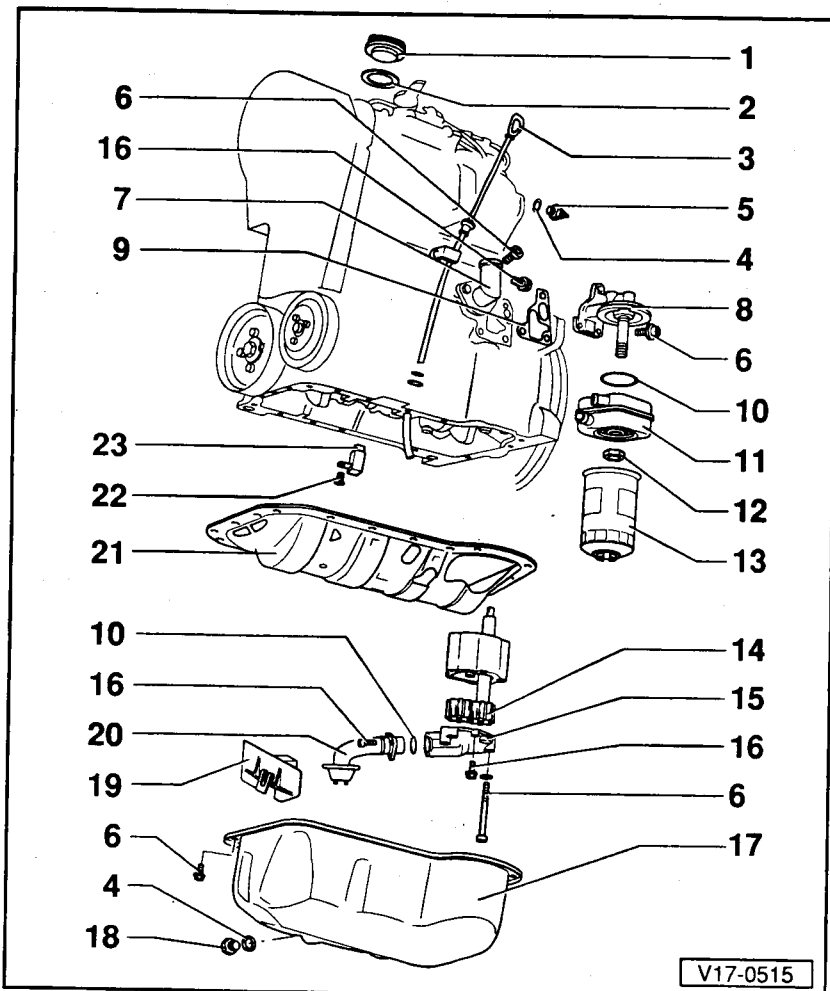

- 1 - Oil filler cap
- 2 - Seal
 - ◆ Renew if damaged
- 3 - Dipstick
 - ◆ Quantity difference between marks
min. ... max.: 1.0l
- 4 - Seal
 - ◆ If leaking nip open and renew
- 5 - 0.3 bar oil pressure switch (F22), 25 Nm
 - ◆ Brown
 - ◆ Checking ⇒ Page 17-7
- 6 - 20 Nm
- 7 - Crankcase breather
- 8 - Oil filter bracket
- 9 - Gasket
 - ◆ Renew

V17-0515

17-2

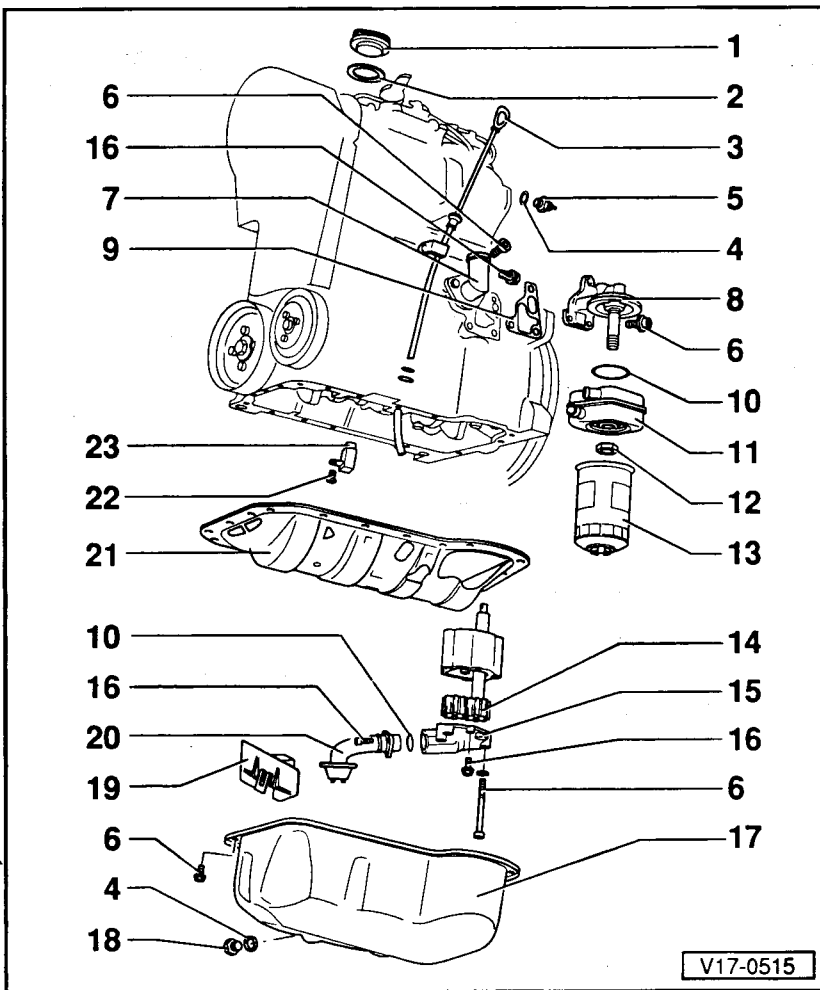

- 10 - O-ring
 - ◆ Renew
- 11 - Oil cooler
 - ◆ Coat contact surface to oil filter bracket outside sealing ring with AMV 188 100 02
 - ◆ Ensure clearance to adjacent components
 - ◆ Observe note ⇒ Page 17-1
- 12 - 25 Nm
- 13 - Oil filter
 - ◆ Loosen with strap wrench
 - ◆ Tighten by hand
 - ◆ Observe installation instructions on oil filter
- 14 - Oil pump gears
 - ◆ Checking backlash ⇒ Fig. 1
 - ◆ Checking axial play ⇒ Fig. 2
 - ◆ Width of gears 36 mm

————— 17-3 —————

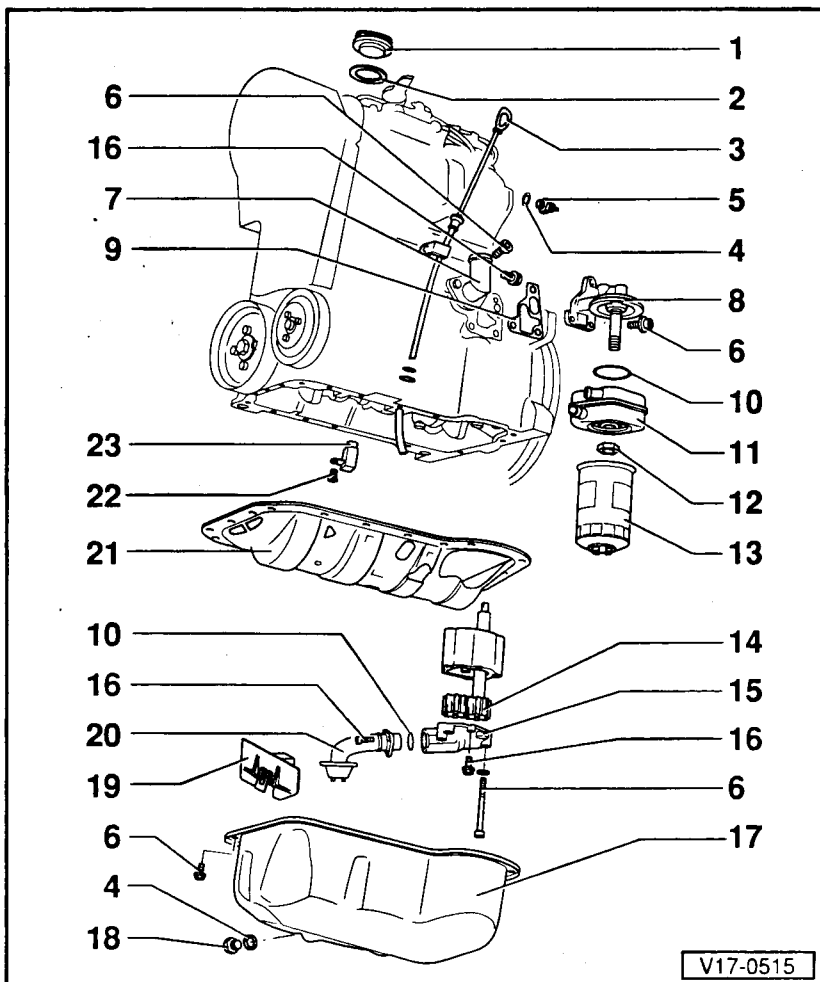

- 15 - Oil pump with pressure relief valve
 - ◆ Opening pressure: 5.7...6.7 bar
- 16 - 10 Nm
- 17 - Sump
 - ◆ Clean sealing surface before installing
 - ◆ Remove both rear bolts to gear-box with jointed spanner 3185
- 18 - Oil drain plug, 30 Nm
- 19 - Baffle plate
- 20 - Suction pipe
 - ◆ Clean strainer if soiled
- 21 - Baffle tray

————— 17-4 —————

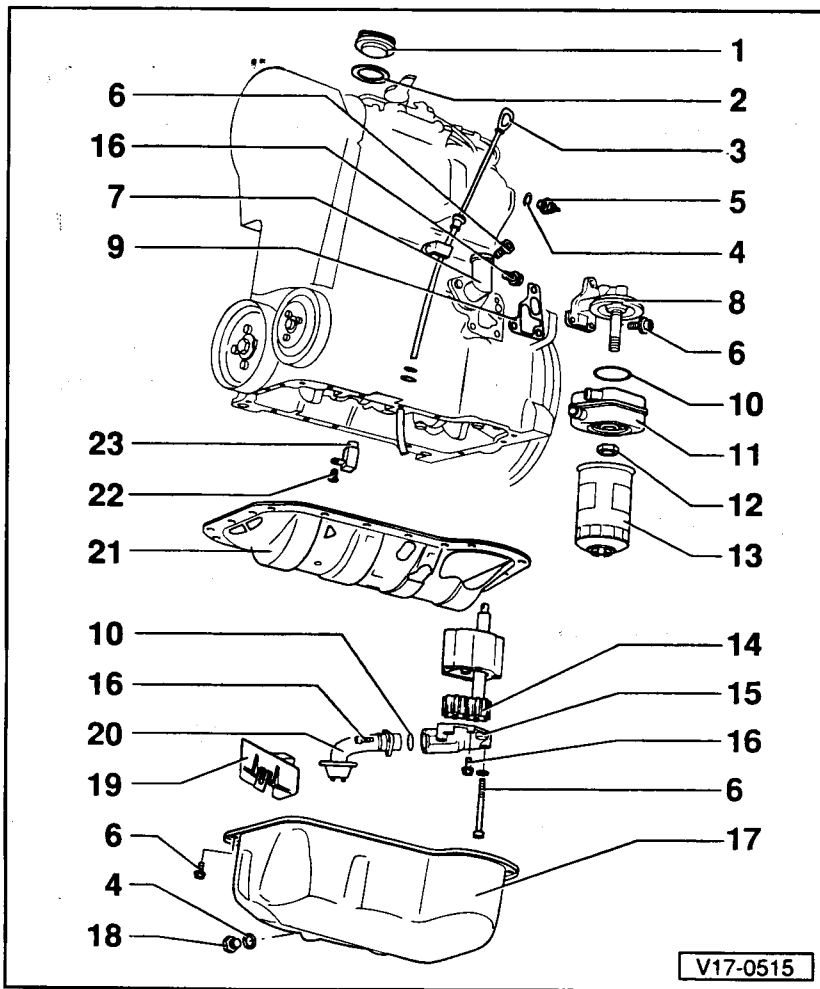

22 - 10 Nm
 ♦ Install with AMV 188 100 02

23 - Oil spray jet
 ♦ For piston cooling

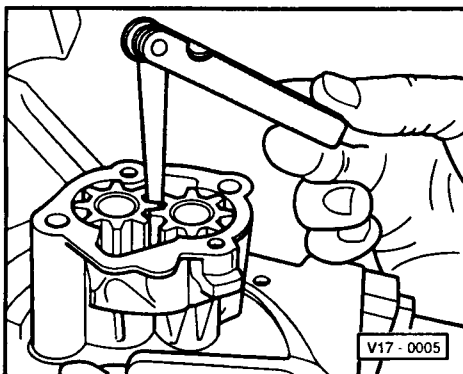

◀ - Fig. 1 Checking oil pump backlash

New: 0.05 mm

Wear limit: 0.20 mm

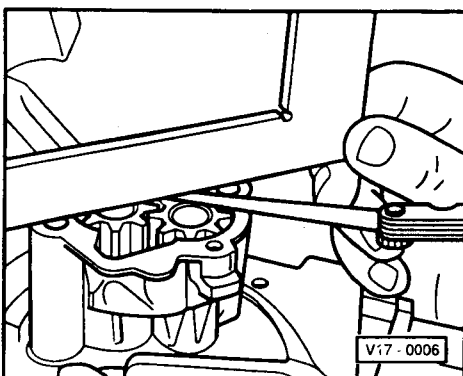

◀ - Fig. 2 Checking oil pump axial play

Wear limit: 0.15 mm

Checking oil pressure and oil pressure switch

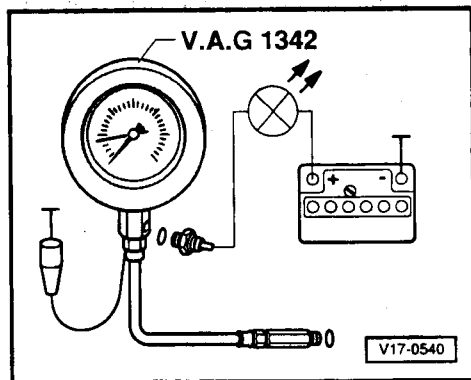

- ◀ - Remove 0.3 bar oil pressure switch (brown insulation) and screw into the tester.
- Screw the tester into the cylinder head in the place of the oil pressure switch.
- Connect brown wire from tester to earth (-).
- Connect diode test lamp V.A.G 1527 to battery positive (+) and 0.3 bar oil pressure switch using aux. cables from V.A.G 1594.

LED must light up.

- Start engine and slowly increase engine speed.

At a pressure of 0.15...0.45 bar the LED must go out.

- Otherwise, renew oil pressure switch.
- Increase engine speed further.

At 2000 rpm and an engine oil temperature of 80°C, the pressure should be a minimum of 2.0 bar.

Removing and installing parts of cooling system

Note:

- ♦ When the engine is warm, the cooling system is under pressure. If necessary release pressure before carrying out repair work.
- ♦ Hose connections are secured with either spring-type or screw-type clips. In cases of repair spring-type clips can be replaced by screw-type clips
- ♦ Commercially available pliers e.g. Hazet 798-5 are recommended for fitting spring-type clips

Parts of cooling system engine side ⇒ Page 19-2.

Coolant hose connection diagram ⇒ Page 19-5.

Draining and filling with coolant ⇒ Page 19-6.

Coolant anti-freeze mixing ratios
⇒ Page 19-6, Draining and with filling coolant.

Carry out leakage test of cooling system with V.A.G 1274 and 1274/1A.

19-1

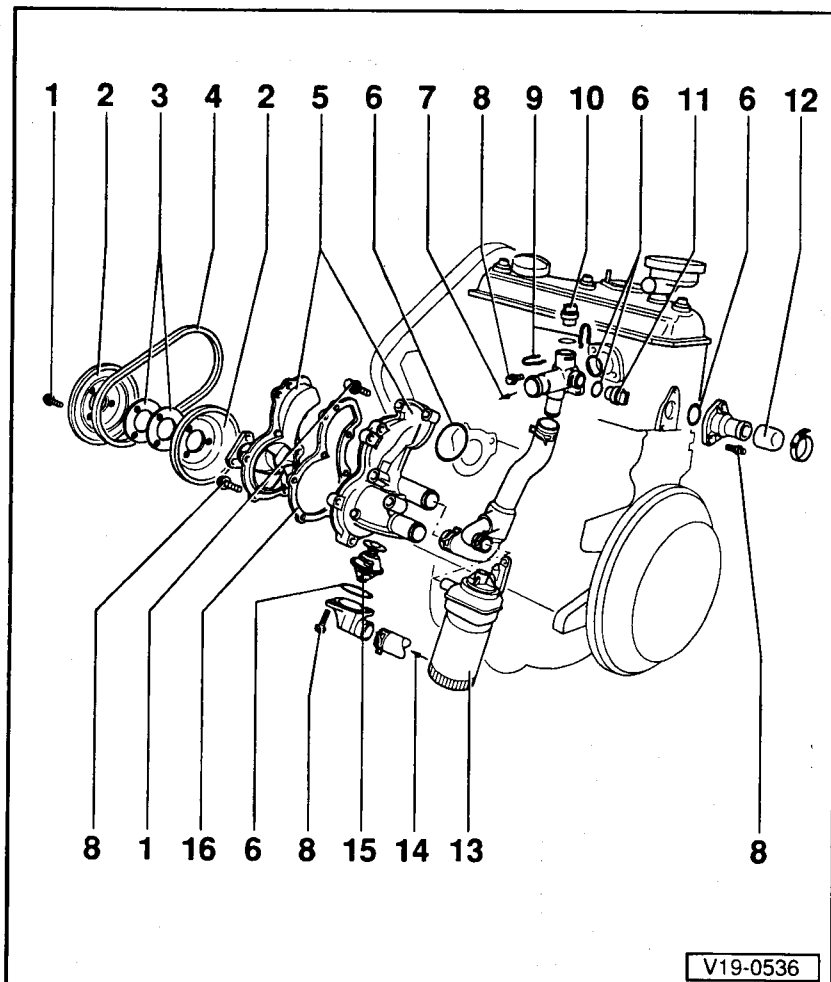

Parts of cooling system - engine side

- 1 - 25 Nm
- 2 - Belt pulley
- 3 - Spacer washers
 - ♦ Adjust V-belt tension by inserting or removing spacer washers between the two halves of the pulley
 - ♦ Screw in threaded pin (M8 x 30) to align the individual parts then insert both normal securing bolts and remove the threaded pin
- 4 - Coolant pump V-belt
 - ♦ Check tension with thumb pressure
 - max. deflection:
new V-belt approx. 2 mm
used V-belt approx. 5 mm

19-2

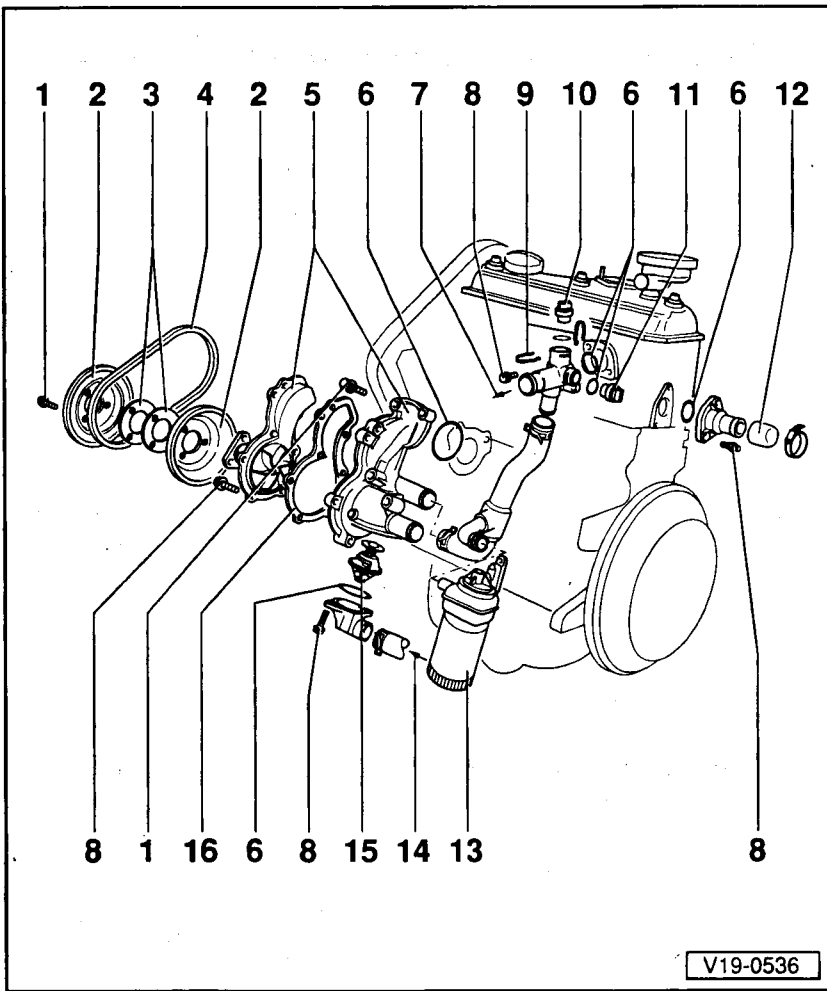

- 5 - Coolant pump
 - ◆ Check that shaft rotates easily
- 6 - O-ring
 - ◆ Renew
- 7 - To top of radiator
- 8 - 10 Nm
- 9 - Retaining clip
- 10 - Coolant temperature switch (F14)
 - ◆ Switching temperature 107...113°C
- 11 - Glow plug system sender (G27)
- 12 - Sealing cap
- 13 - Oil filter with oil cooler
 - ◆ Removing and installing ⇒ Page 17-3
- 14 - From bottom of radiator

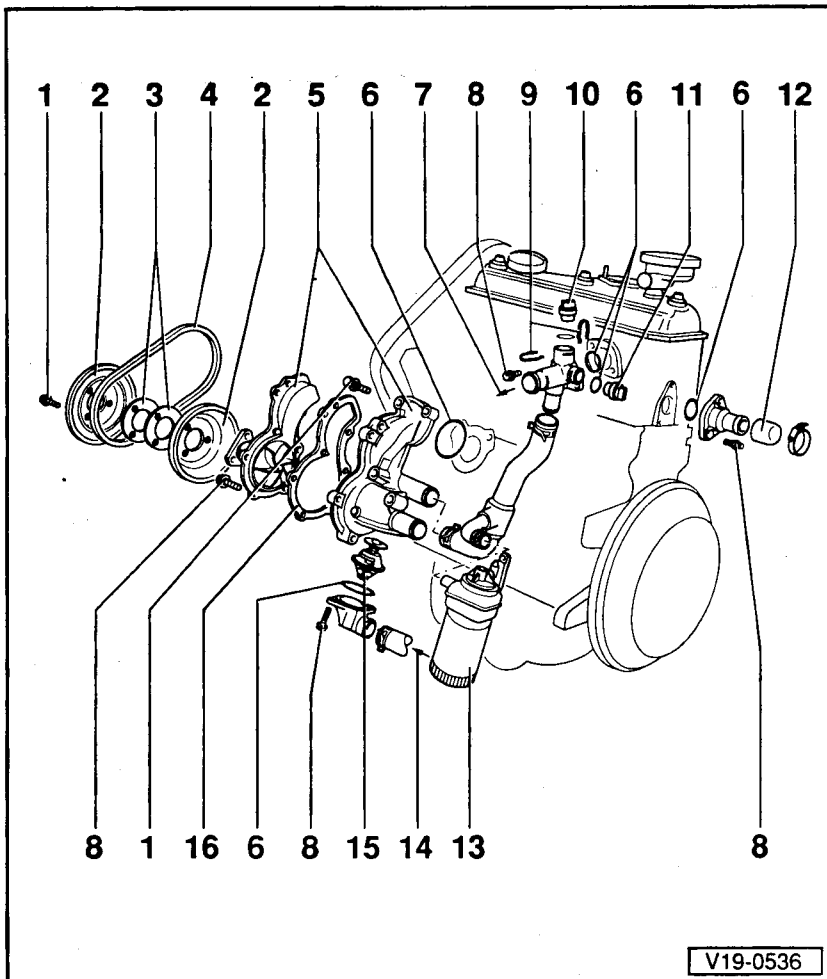

- 15 - Coolant thermostat
 - ◆ Checking: heat thermostat in water
 - ◆ Opening starts at approx. 70°C
 - ◆ Ends at approx. 85°C
 - ◆ Opening lift at least 7 mm
- 16 - Gasket
 - ◆ Renew

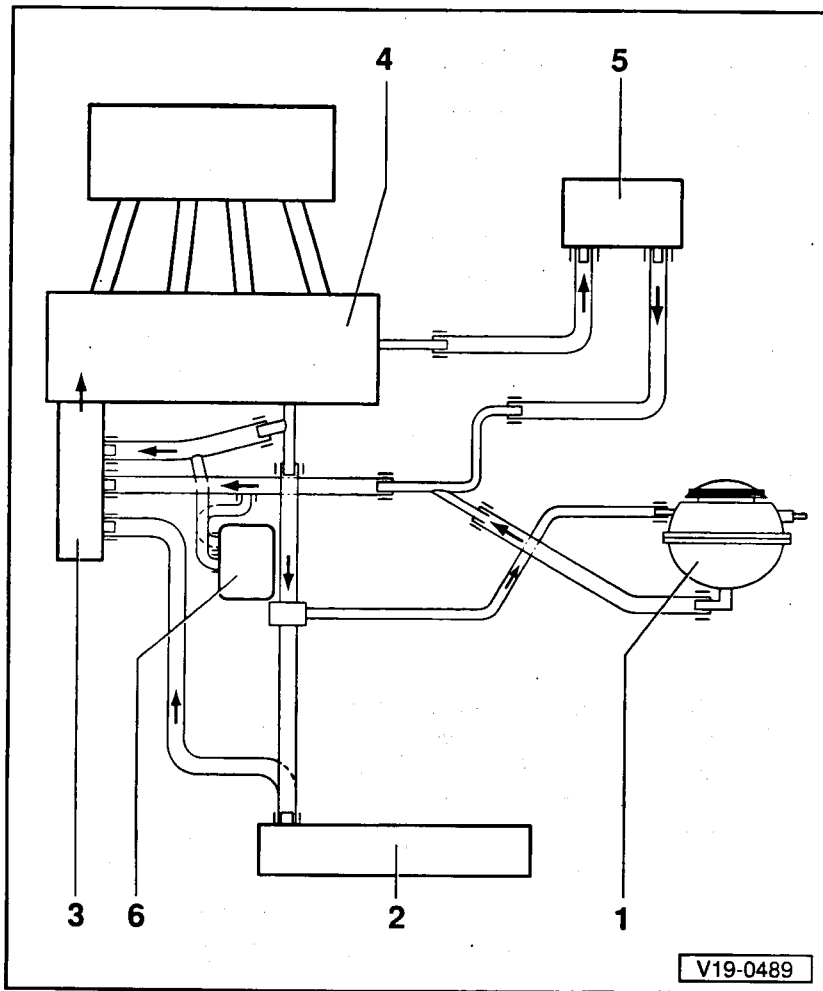

Coolant hose connection diagram

- 1 - Expansion tank
- 2 - Radiator
- 3 - Coolant pump with thermostat
- 4 - Cylinder head/cylinder block
- 5 - Heat exchanger for heating
- 6 - Oil cooler

19-5

Draining and filling with coolant

Draining

- Remove the expansion tank cap.
- ◀ - Drain coolant:
either from coolant hose -1-
or via coolant pump flange -2-.

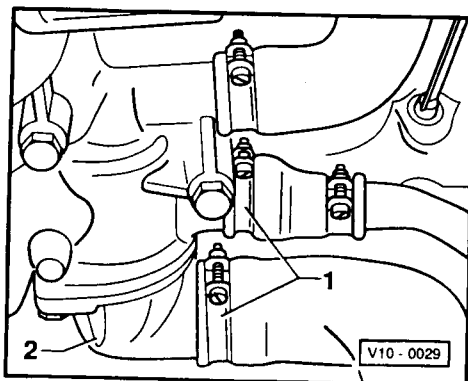

Filling

Note:

- ◆ *The cooling system must be kept filled all year round with a mixture of water and coolant anti-freeze and corrosion protection additive G11. G11 and the coolant additives marked with designation "conforms to TL VW 774 B" prevent frost and corrosion damage, the formation of scale and, in addition, they raise the boiling-point temperature of the coolant. For these reasons, the cooling system must be filled with this mixture all year round. Due to its high boiling point, the coolant is an aid to operational efficiency especially when the engine is operating at full load, particularly in tropical climates.*
- ◆ *If the radiator, the heat exchanger, cylinder head, or the cylinder head gasket have been renewed, do not reuse the old coolant.*

19-6

Recommended mixture ratios:

Frost protection to	G11 ¹⁾	Water
-25° C	40 %	60 %
-35° C	50 %	50 %

¹⁾ The anti-freeze proportion must not exceed 60%.
The anti-freeze and cooling effects are reduced if the proportion is too large.

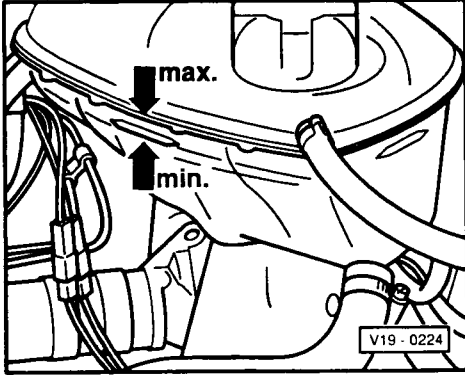

- ◀ - Fill the coolant up to the maximum mark the expansion tank.
- Fit expansion tank cap.
- Run the engine until the radiator fan runs.
- Check the coolant level and top up if necessary. When the engine has reached its operating temperature, the coolant level must be on the maximum mark and, in the case of a cold engine, it should lie between the minimum and maximum mark.

Removing and installing parts of exhaust gas turbo charging system

Rules for cleanliness ⇒ Page 21-4

Note:

- ◆ All hose connections are secured with hose clips.
- ◆ Gaskets and sealing rings must always be renewed.

1 - Gasket

- ◆ Coating (beading) to intake manifold

2 - Intake manifold

3 - 45 Nm

- ◆ Renew
- ◆ Coat thread and head contact surface with G 000 500

4 - Gasket

- ◆ Observe installation position

5 - Exhaust manifold

6 - 25 Nm

7 - Air hose

8 - From air cleaner

9 - Exhaust gas turbo charger

- ◆ Removing and installing ⇒ Page 21-5
- ◆ Checking charge pressure ⇒ Page 21-6

10 - Wastegate

- ◆ Component part of turbo charger cannot be replaced

11 - Sealing ring

- ◆ Renew

12 - 50 Nm

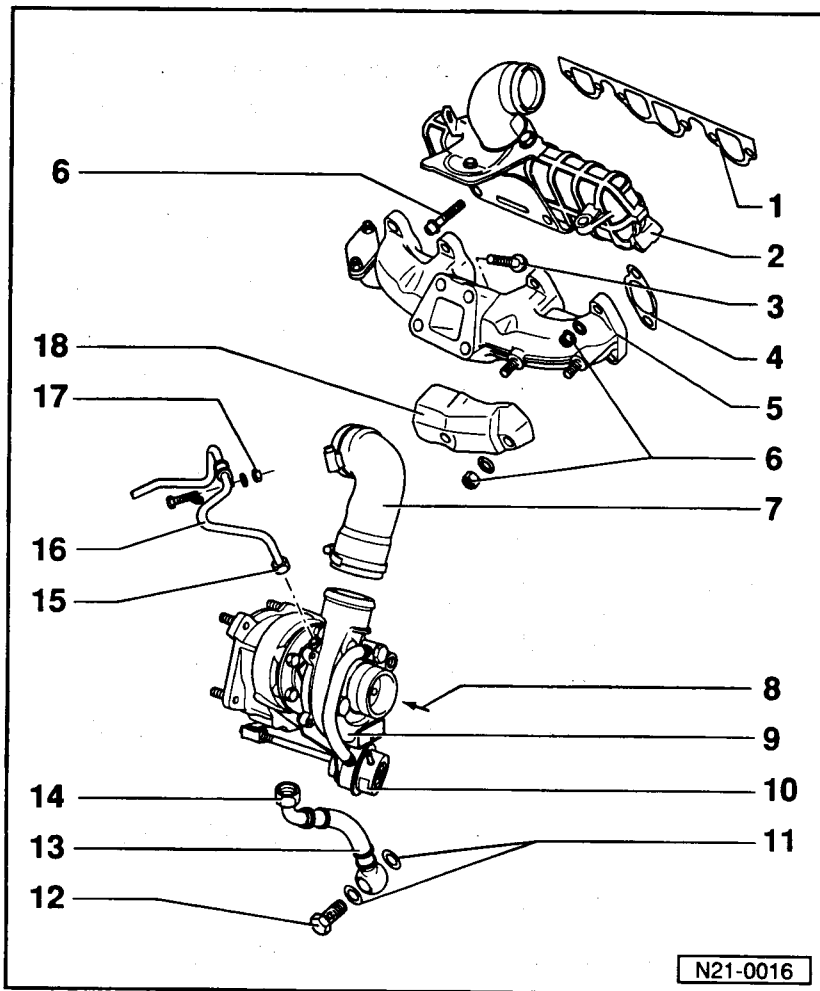

21-1

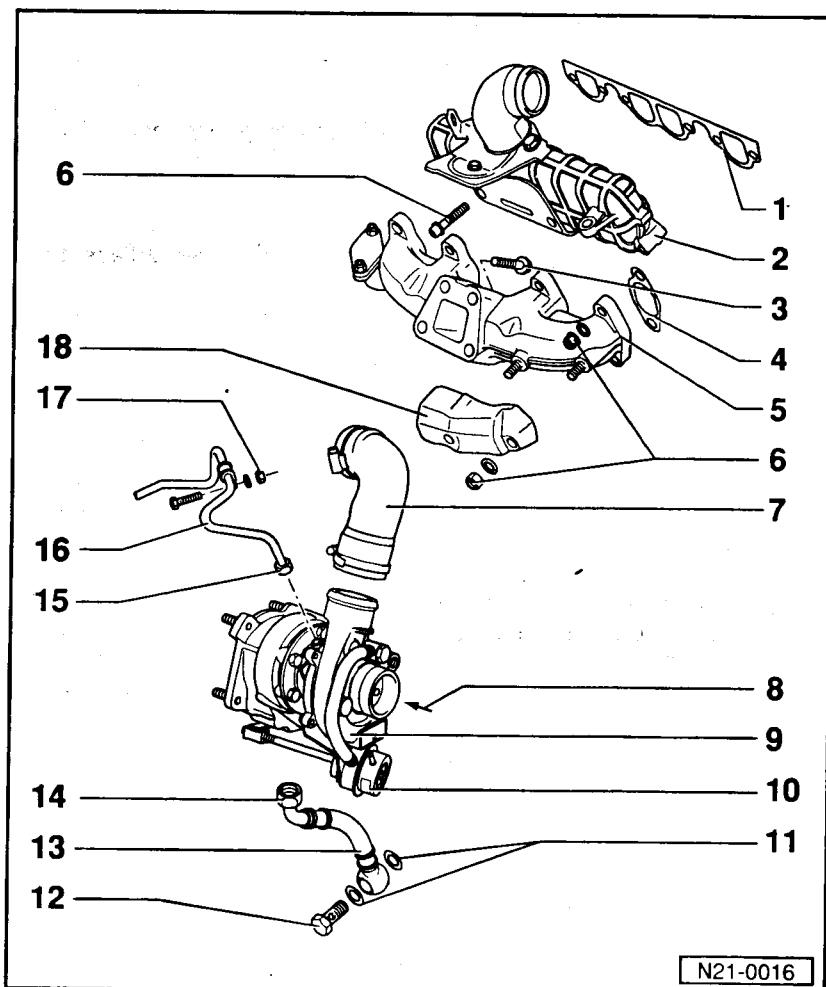

21-2

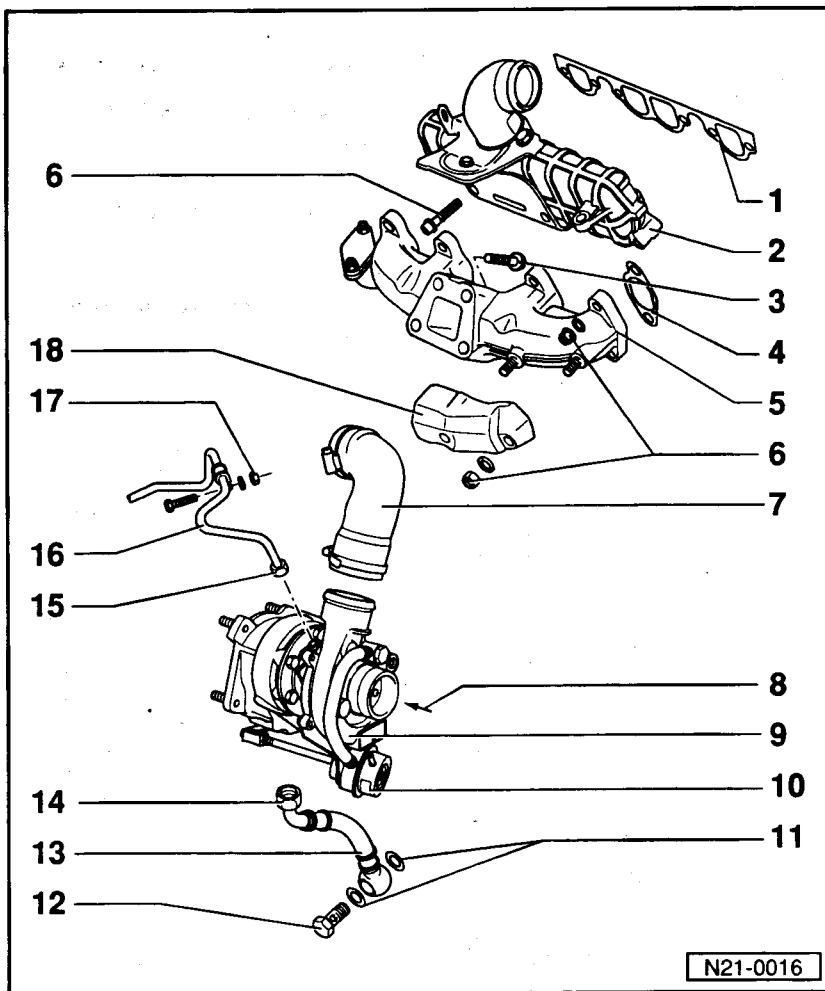

- 13 - Oil return pipe
♦ To cylinder block
- 14 - 40 Nm
- 15 - 25 Nm
- 16 - Oil feed pipe
♦ From oil filter bracket
- 17 - 10 Nm
- 18 - Heat shield

21-3

Rules for cleanliness

When working on the turbo charging system, the following "5 rules" for cleanliness are to be carefully observed :

- ♦ Thoroughly clean all connections and their adjacent areas before detaching.
- ♦ Place parts which have been removed on a clean surface and cover them with plastic sheet or paper. Do not use fluffy cloths!
- ♦ Components which have been opened should be carefully covered or sealed if repair cannot be carried out immediately.
- ♦ Install clean components only:
Only unpack replacement parts immediately before installation.
Do not use parts which have been kept unpacked (e.g. in tool boxes, etc.).
- ♦ When the system is open:
Do not use compressed air, if it can be avoided.
Do not move the unit unless absolutely necessary.

21-4

Removing and installing turbo charger

Removing

- With ignition switched off disconnect battery earth strap.
- Remove air hose between intake manifold/turbo charger and turbo charger/air cleaner.
- Detach oil feed pipe from turbo charger and securing clamps/intake manifold.
- Detach oil return pipe from turbo charger
- Detach exhaust pipe from turbo charger
- ◀ - Remove 4 securing bolts -arrows- between turbo charger exhaust manifold (with ring spanner or joint spanner 3205).

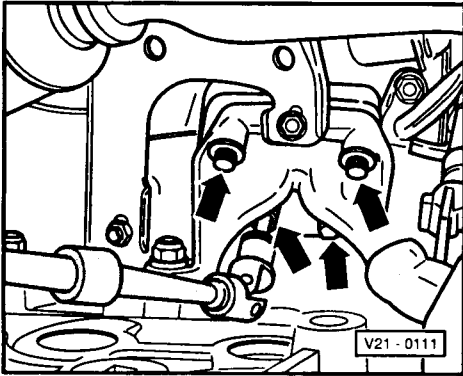

Installing

Note the following when installing:

- Fit turbo charger and tighten securing nuts on exhaust pipe so that the turbo charger can still be moved.
- Insert 4 turbo charger/exhaust manifold securing bolts and tighten fully. Then tighten nuts to exhaust manifold.

————— 21-5 —————

- Before attaching the oil feed pipe fill turbo charger with engine oil through connection.
- After fitting turbo charger do not rev up immediately allow engine to idle for about 1 minute , so that the oil supply to the turbo charger is guaranteed.

Checking exhaust gas turbo charger

The exhaust gas turbo charger and wastegate form one unit. If the turbo charger is defective it can only be exchanged, as a repair with normal workshop equipment is not possible.

Prerequisites for trouble-free functioning of the exhaust gas turbo charger and attaining the prescribed charge pressure are:

- No leaks on intake and exhaust sides.
- Control pipe to wastegate not blocked, loose leaking
- No faults on engine/injection system like commencement of injection, max. governed speed, injectors, compression pressures

————— 21-6 —————

The charge pressure is measured at full load. Test duration per measurement maximum 10 seconds.

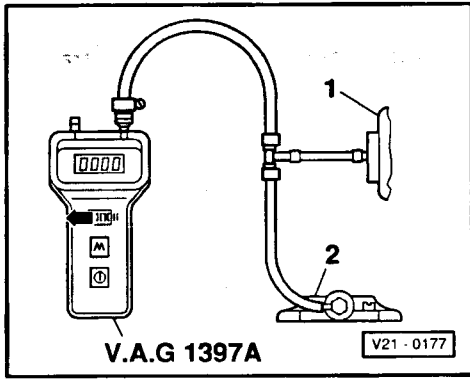

- ◀ - Pull off connecting hose between intake manifold -1- and injection pump -2- at one end and connect to turbo charger tester T-piece.

Note:

- ◆ *Using turbo charger tester see Operating Instructions*
- ◆ *The hoses must be connected absolutely free of leaks.*

- Check charge pressure at full load.
Specification:
0.60...0.83 bar (relative pressure)
- If the specification is not attained, replace turbo charger.
- If the charge pressure is too high, also replace turbocharger, as the wastegate is defective.

Servicing fuel injection system

Rules for cleanliness ⇒ Page 23-9.

Removing and installing the fuel filter
⇒ Page 23-6.

Adjusting the cold starting accelerator cable
⇒ Page 23-10.

Checking and adjusting valve timing
⇒ Page 23-18.

Checking and adjusting idling and governed speeds
⇒ Page 23-20.

Note:

- ◆ Hose connections are secured with screw-type or clamp-type clips.
- ◆ Always renew the clamp-clips with screw-type clips.
- ◆ Always renew gaskets and sealing rings.

23-1

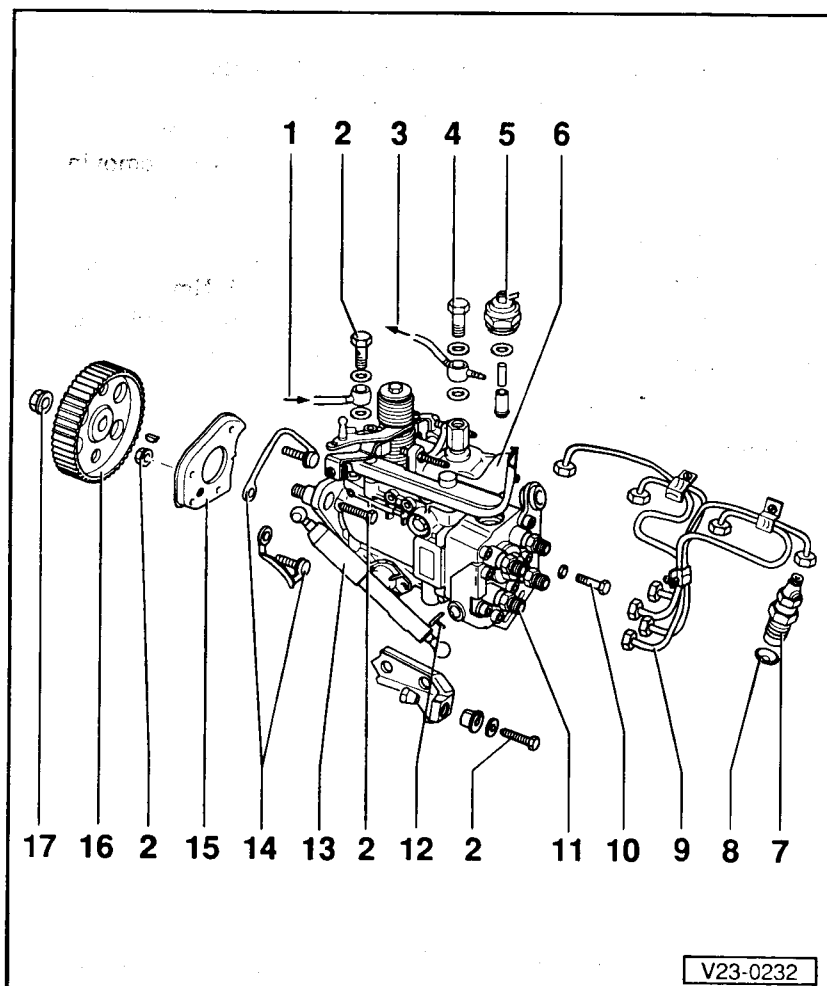

1 - From fuel filter

2 - 25 Nm

3 - To fuel tank

4 - 25 Nm

- ◆ Banjo bolt for return pipe
- ◆ Is marked with "OUT"

5 - Fuel shut-off valve (N109), 40 Nm

- ◆ Must click when ignition is switched on and off

V23-0232

23-2

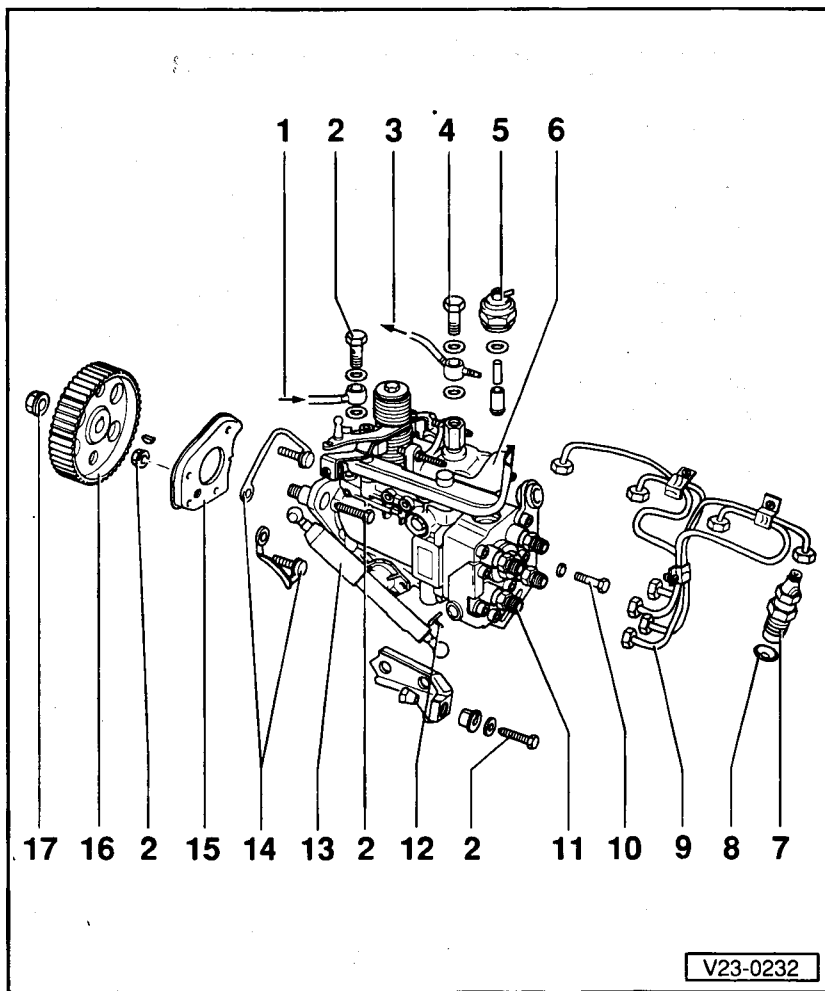

6 - Injection pump

- ◆ Engine code ADE with charge pressure enrichment
- ◆ Removing and installing
⇒ Page 23-11
- ◆ Checking and adjusting commencement of injection
⇒ Page 23-15
- ◆ If the pump is defective, it must be exchanged, as an injection pump test bench is required in order to repair it
- ◆ Engine code ADE:
Open CPE housing vent ⇒ Fig. 1

7 - Injector, 70 Nm

- ◆ Removing and installing
⇒ Page 23-22
- ◆ Checking and adjusting ⇒ Page 23-23, Servicing injectors
- ◆ Servicing ⇒ Page 23-23

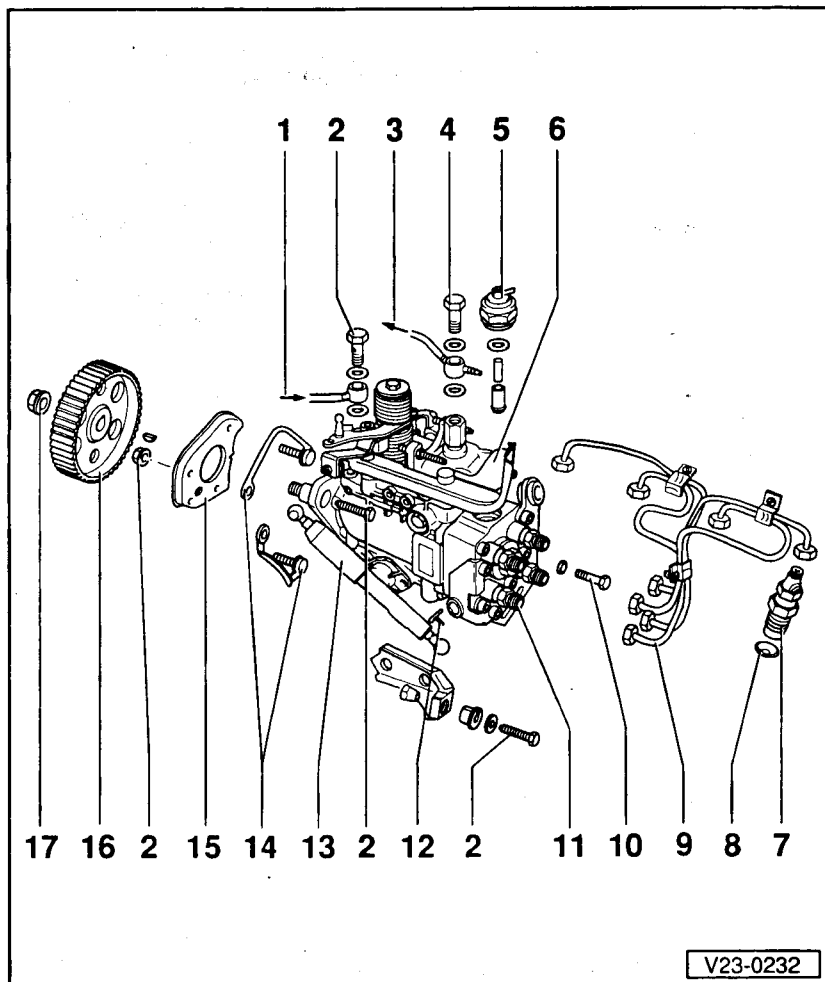

8 - Heat shield seals

- ◆ Renew
- ◆ Installation position
⇒ Page 23-22, removing and installing injectors

9 - Injector pipes

- ◆ Tighten to 25 Nm
- ◆ Remove and install using an open ring spanner 3035
- ◆ Always remove pipe set complete
- ◆ Do not alter shape

10 - 15 Nm

- ◆ If leaking tightening to max. 25 Nm is permitted

11 - Connection adapters

- ◆ Sealing ⇒ Page 23-20

12 - Retainer

13 - Damper

- ◆ For load change damping

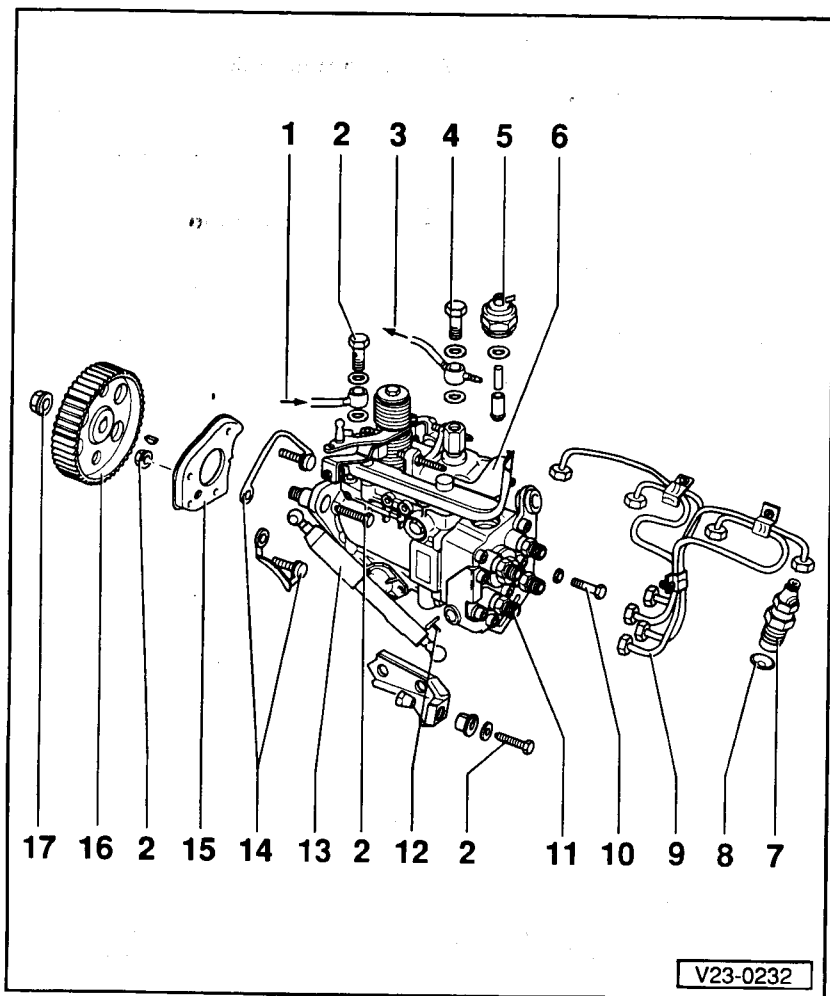

- 14 - Retainer
- 15 - Bracket
- 16 - Injection pump sprocket
 - ◆ Removing ⇒ page 23-11, removing injection pump
- 17 - 45 Nm

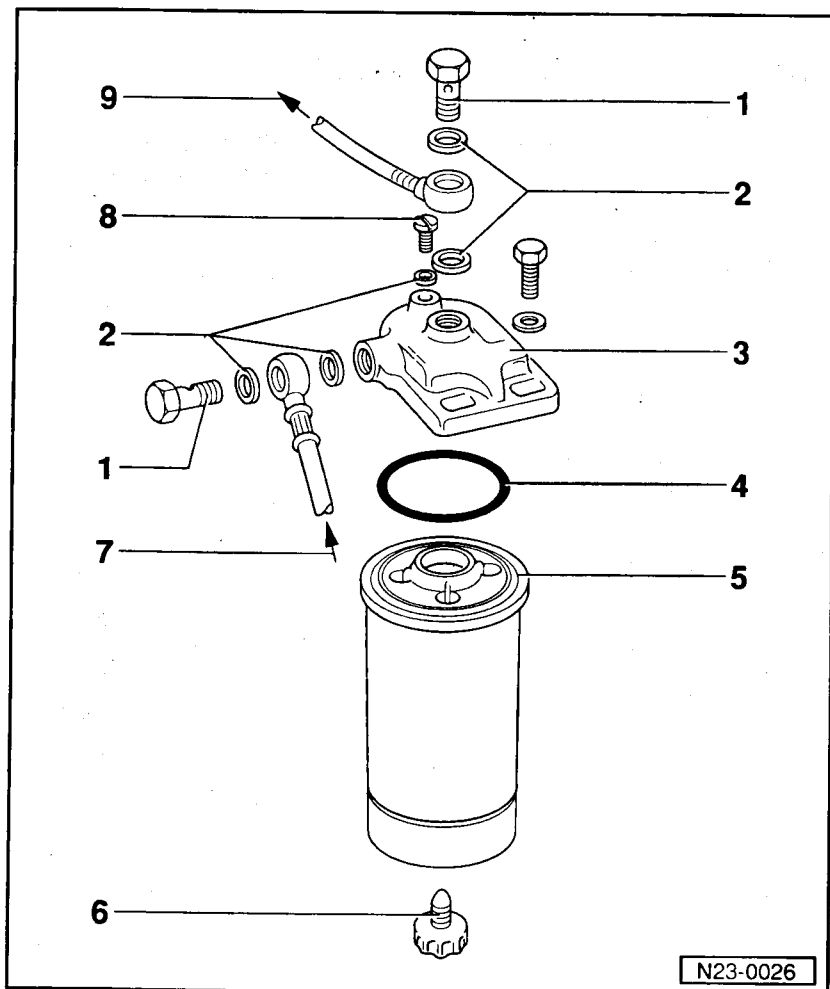

Removing and installing fuel filter

- 1 - 25 Nm
- 2 - Sealing ring
 - ◆ Renew if damaged
- 3 - Fuel filter upper part
- 4 - O-Ring
 - ◆ Renew
 - ◆ Moisten with fuel before installing filter
- 5 - Fuel filter
 - ◆ Loosen with oil filter spanner (e.g. Matra W 167)
 - ◆ Tighten by hand
- 6 - Water drain plug
 - ◆ Slacken off and allow approx. 100 cm³ fluid to drain off

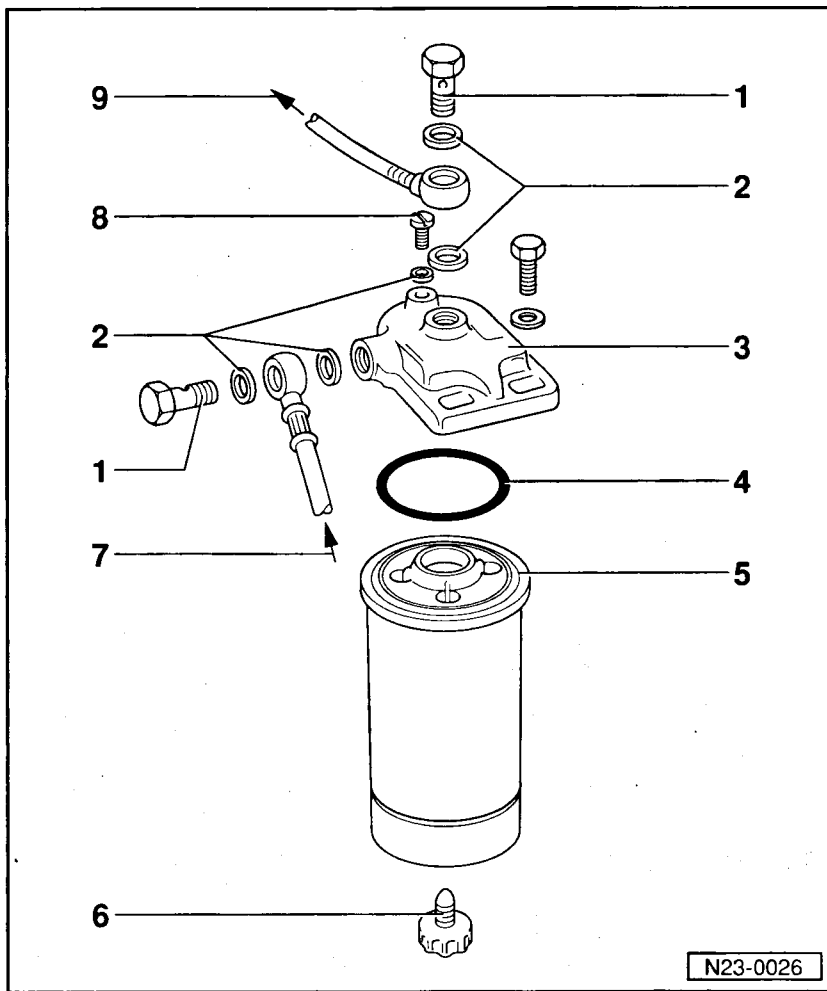

7 - From fuel tank

8 - Bleed screw
 ♦ Loosen to drain water

9 - To injection pump

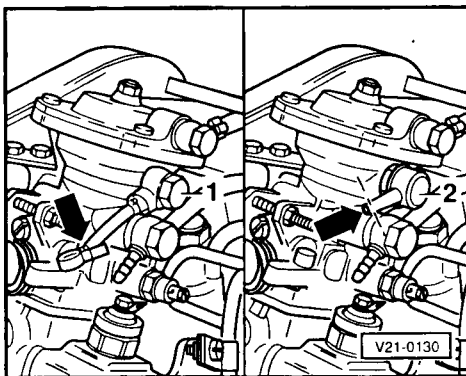

◀ Fig. 1 Opening venting for CPE housing

On replacement injection pumps the CPE housing is sealed and must be opened as follows after installing the pump:

- ♦ Pumps with vent hose -1-
- Remove sealing clamp -arrow-
- ♦ Pumps with rubber cap -2-
- Cut tip off the rubber cap, so that the vent opening -arrow- is free.

Rules for cleanliness

When working on the fuel supply injection system, the following "5 rules" for cleanliness are to be carefully observed:

- ◆ Thoroughly clean connections and their adjacent areas before detaching.
- ◆ Place parts which have been removed on a clean surface and cover them with plastic sheet or paper. Do not use fluffy cloths!
- ◆ Components which have been opened should be covered carefully or sealed if repair cannot be carried out immediately.
- ◆ Install clean components only:
Only unpack replacement parts immediately before installation.
Do not use parts which have been kept unpacked (e.g. in tool boxes, etc.).
- ◆ When the system is open:
Do not use compressed air, if it can be avoided.
Do not move the unit unless absolutely necessary.

Also ensure that no diesel fuel runs onto the coolant hoses. If it does, the hoses must be cleaned immediately. Hoses which have already been affected by diesel fuel must be renewed.

23-9

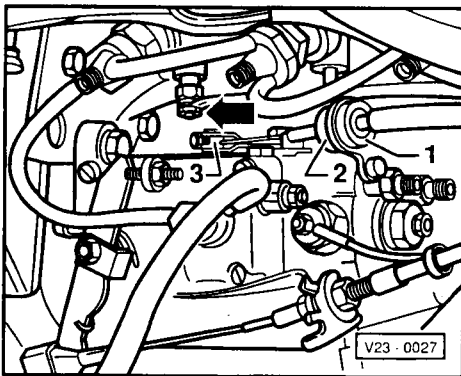

Adjusting cable for cold start accelerator

- ◀ - Slide washer -1- onto the cable and secure cable with retaining washer -2-.
- Move operating lever to 0-position -direction of arrow-. Pull the cable taut and secure it in locating nipple -3- with the clamping screw.

Note:

On engines without cold start accelerator cable the operating lever on the injection pump is locked in the 0-position.

23-10

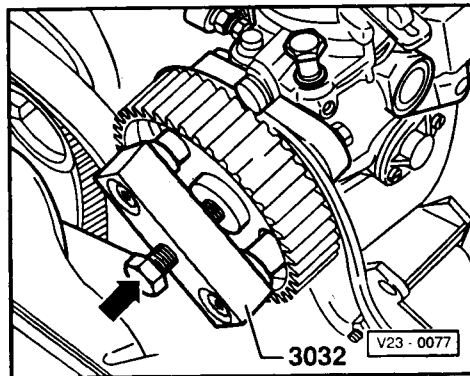
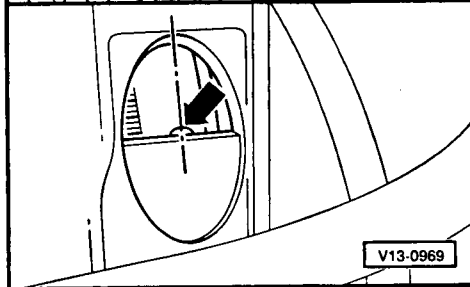
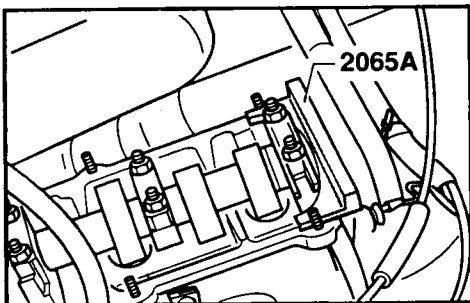

Removing and installing injection pump

Removing

- ◀ - Rotate crankshaft to TDC No. 1 cylinder -arrow-.
- Lock camshaft with setting jig 2065A
- Align setting jig 2065A as follows:
Turn camshaft until one end of setting jig contacts the cylinder head. Measure gap at other end of setting jig with feeler gauges. Place feeler gauge with half of this dimension between setting jig and cylinder head. Turn camshaft until the setting jig contacts the feeler gauge. Place a second feeler gauge of same size between other end of setting jig and cylinder head.
- Remove toothed belt from camshaft and injection pump sprockets.
- Remove injection pump sprocket securing nut.
- ◀ - Loosen puller arms and fit puller.
- Align puller arms to the holes in the injection pump sprocket and tighten.

23-11

- Place injection pump sprocket under tension with puller.
- Loosen injection pump sprocket from taper on shaft by tapping lightly on the puller spindle -arrow- (when doing this hold sprocket so that it cannot fall down).
- Detach all fuel pipes from injection pump and cover openings with a clean cloth.

Note:

Use open ring spanner 3035 to loosen injector pipe unions.

- Detach fuel shut-off electric wire.
- Detach accelerator cable and cold start accelerator cable.

- ◀ - Remove securing bolts from console -2- (qty. 3).

Note:

Remove the lower and the right securing bolts on the console from the front.

- Remove securing bolt from rear support -1-.

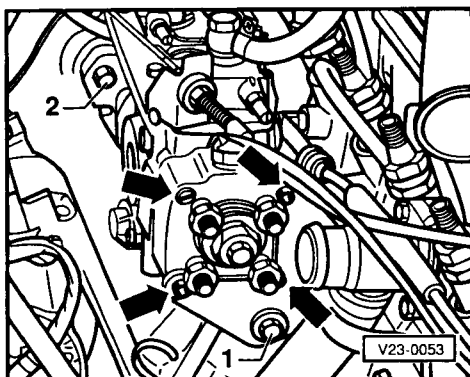

23-12

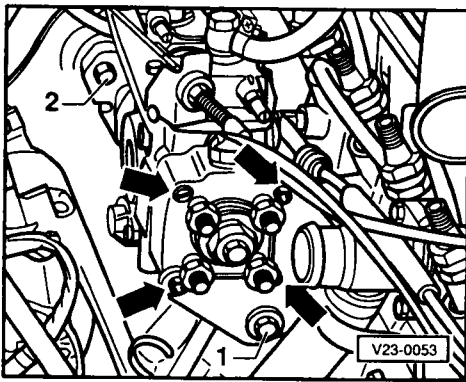

Note:

- ◀ - On no account must the injection pump head securing bolts be loosened. Loosening the securing bolts leads to the head being tilted and will break the distributor piston.

Installing

- Install injection pump and align to the centre position in the elongated holes in flange.

Tightening torques

Securing bolts	25 Nm
Fuel pipes	25 Nm
Injection pump sprocket	45 Nm

Note:

Do not interchange the banjo bolts for supply and return pipes, the return pipe banjo bolt has a smaller drilling and is marked with "OUT" on the hexagon head.

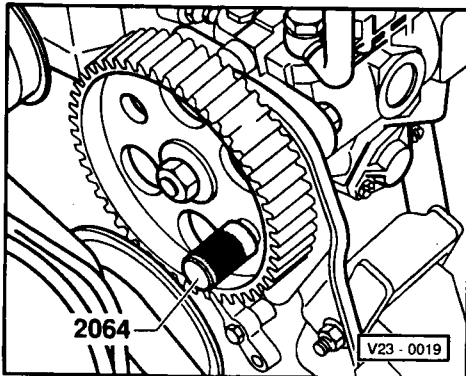

- ◀ - Install the injection pump sprocket and lock with locating pin 2064.

- Loosen camshaft sprocket securing bolt 1/4 a turn. Loosen camshaft sprocket from taper on camshaft by striking with hammer (with a drift through the hole in the rear toothed belt guard).

- Check that the flywheel TDC mark is aligned with the reference mark.

- Fit toothed belt and remove locating pin from camshaft sprocket.

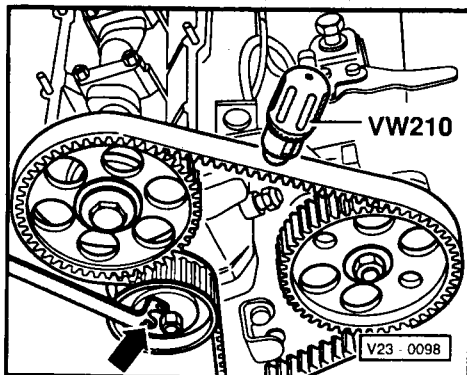

- ◀ - Tension toothed belt (turn tensioning roller to right with pin wrench e.g. Matra V159 -arrow-).

Scale value: 12...13

measured between camshaft sprocket and injection pump sprocket.

- Tighten camshaft sprocket securing bolt to 45 Nm

- Remove setting jig

- Turn crankshaft two turns in engine direction of rotation and again check that toothed belt tension is to specification.

- Check commencement of injection ⇒ Page 23-15.

- Check and adjust idling speed and governed speed ⇒ Page 23-20

Checking and adjusting injection pump commencement of injection

Test and adjustment conditions

- Toothed belt tension OK
- Cold start accelerator cable must not be pulled (injection pump operating lever in 0-position)
- Set engine to TDC on No. 1 cylinder:

Engine installed

- ◀ - Rotate the crankshaft until the flywheel TDC mark aligns with the casting on the clutch bell housing

Engine removed

- ◀ - Attach setting tool as shown
 - Adjust setting tool to
 - Engine code 028.B, ADG
 - 12V version: 110.0 mm
 - 24V version: 112.8 mm
 - Engine code ADE 108.5 mm
- The reference point is the graduation on the left of the vernier scale -arrow A-

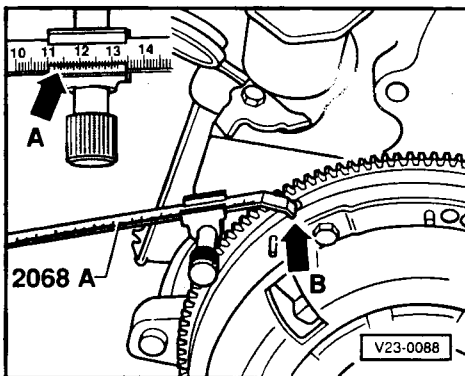
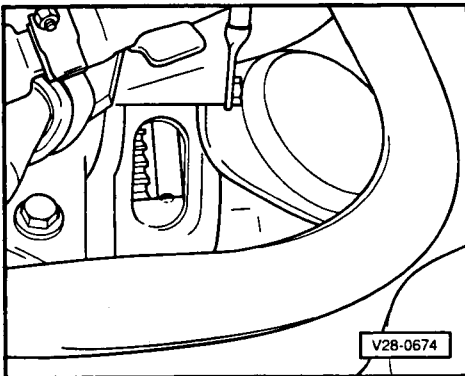

23-15

- Turn crankshaft until flywheel TDC mark aligns with the point of the setting tool -arrow B-

Checking and adjusting

- Unscrew sealing plug from injection pump head.

Note:

- ◆ Always renew the sealing plug sealing ring.
- ◆ Tightening torque 15 Nm.
- ◆ In the case of leakage, tightening to a maximum of 25 Nm is permissible.

- ◀ - Install adapter and small dial gauge (measuring range 0..3.0 mm) in place of the sealing plug and preload the gauge to about 2.5 mm.
- Rotate the crankshaft slowly in the opposite direction to engine direction of rotation until the dial gauge needle stops moving.
- Set the dial gauge to "0" with about 1 mm preload.
- Rotate the crankshaft in the engine direction of rotation until the TDC marking on the flywheel is in alignment with the reference mark on the clutch housing.

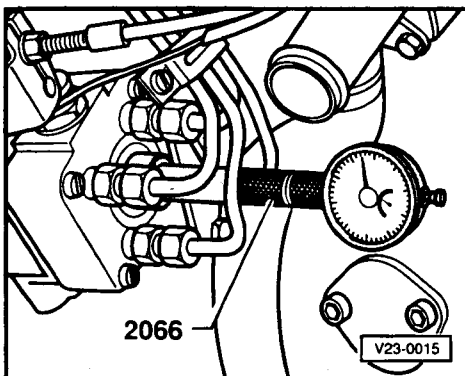

23-16

- Read off the commencement of injection on the dial gauge.

Engine codes 028.B, ADG:

Test value 0.93...1.07 mm lift

Setting value 1.00 ± 0.02 mm lift

Engine codes ADE:

Test value 0.83...0.97 mm lift

Setting value 0.90 ± 0.02 mm lift

Note:

If the test value is within the specified tolerance, no adjustment is required.

- Loosen the three securing bolts on the console and the rear support securing bolt.
- Adjust injection pump commencement of injection to specification by turning injection pump.
- Tighten securing bolts to 25 Nm.

Checking and adjusting engine valve timing

- Remove cylinder head cover and upper part of toothed belt guard.
- Check toothed belt tension.

- ◀ - Rotate the crankshaft to TDC on cylinder No. 1 -arrow-. The setting jig must fit in the recess in the camshaft

- If the setting jig does not fit, adjust valve timing as follows.

- Turn crankshaft so that setting jig can be inserted.

- Align setting jig as follows:

Turn camshaft until one end of setting jig contacts the cylinder head. Measure gap at other end of setting jig with feeler gauges. Place feeler gauge with half of this dimension between setting jig and cylinder head. Turn camshaft until the setting jig contacts the feeler gauge. Place a second feeler gauge of same size between other end of setting jig and cylinder head.

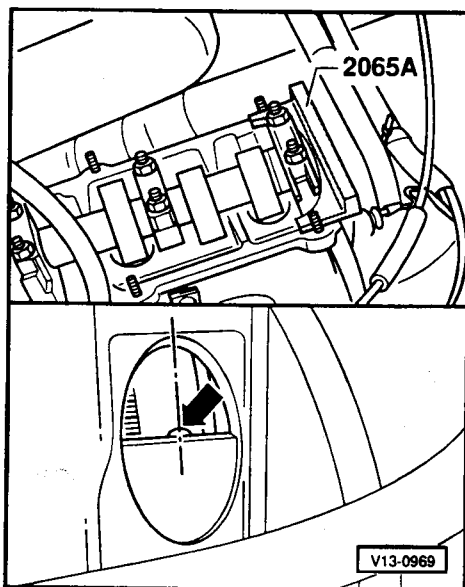

- Loosen camshaft sprocket securing bolt ½ turn. Loosen camshaft sprocket from taper on camshaft by striking with hammer (with drift through the hole in the rear toothed belt guard).

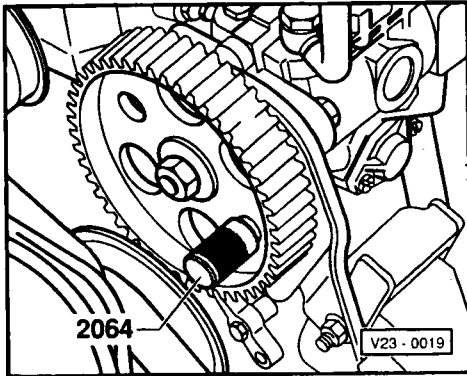

- ◀ - Lock the injection pump sprocket with locating pin 2064.
- Check again if the TDC marking on the flywheel and the reference casting on the clutch housing are in alignment and adjust if necessary ⇒ Page 23-18, Fig. V13-0969.

Note:

It is possible that the toothed belt must be removed to adjust the injection pump sprocket and the TDC mark on flywheel.

- Remove locating pin.
- Tension toothed belt and tighten camshaft sprocket securing bolt to 45 Nm.
- Remove setting jig.
- Check injection pump commencement of injection ⇒ Page 23-15.

Sealing injection pump connecting unions

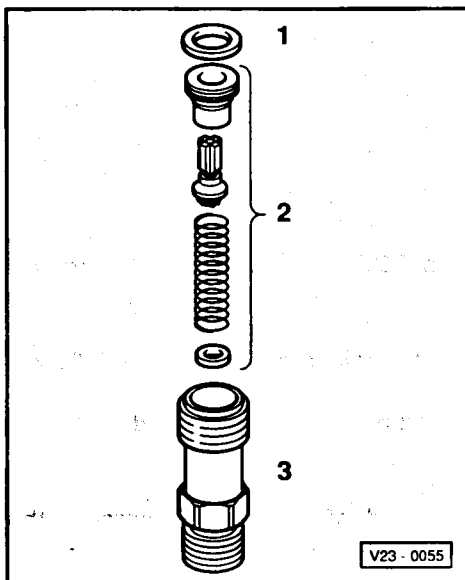

- ◀ 1 - Seal
- 2 - Pressure valve
- 3 - Connecting union
- Loosen injection pipe with open ring spanner 3035.
- Tighten connecting union to 45 Nm.
- Tighten injection pipe to 25 Nm.
- If this does not stop the leak, install a new connecting union and a new sealing washer.

Note:

When replacing the connecting unions, do not interchange the pressure valves.

Adjusting idling speed and governed speed

- Engine oil temperature minimum 60°C
- Cable for cold start accelerator must not be pulled
- Electrical consumers switched off

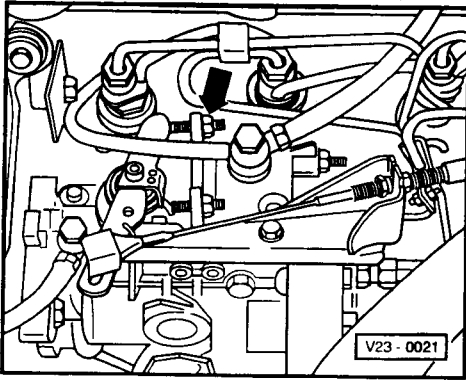

The engine speed can be measured with ignition tester V.A.G 1367 via the TDC sender or via the adapter VW 1324.

Adjusting idling speed or min. governed speed (without load)

- ◀ - Adjust engine speed with idling speed adjustment screw - arrow-, according to the information given on the identification plate for idling speed or min. governed speed without load
- Lock adjustment screw.

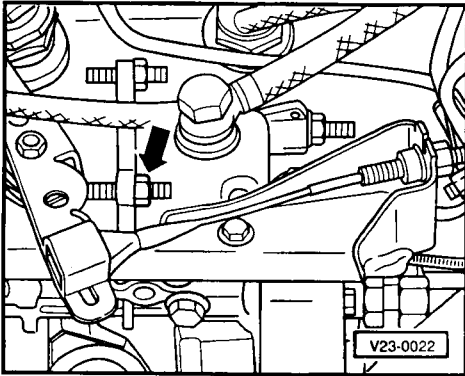

Checking and adjusting the governed speed or the max. governed speed (without load)

- ◀ - Open throttle fully and adjust engine speed with the governed speed adjustment screw -arrow-, according to the information given on the identification plate for the governed speed or maximum governed speed without load.

23-21

Removing and installing injectors

Note:

Defective injectors usually cause the following malfunctions:

- ◆ *Misfiring*
- ◆ *Knocking in one or more cylinders*
- ◆ *Engine overheating*
- ◆ *Loss of power*
- ◆ *Excessively smoky, black exhaust*
- ◆ *Increased fuel consumption*
- ◆ *Excessive blue smoke when starting from cold*

Defective injectors can be located by loosening the pipe union on each injector in turn, with the engine running at fast idle. If the engine speed remains constant after loosening a pipe union, this denotes a faulty injector.

Removing

- ◀ - Detach injector pipes with open ring spanner 3035.

Note:

Always remove the pipe set complete. Do not alter shape of pipes.

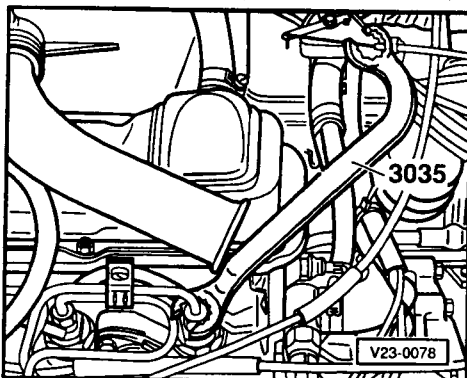

23-22

- Remove injectors with 27 mm socket.

Installing

Note:

Always fit new heat shields between the cylinder head and injectors.

- ◀ Fitting position of heat shield:
Arrow points towards cylinder head

Tightening torques:

Injectors 70 Nm
Injector pipes 25 Nm

Servicing injectors

- ◀ - Clamp the upper part of the injector in a vice and loosen screwed connection.
- To prevent the individual parts falling out, clamp the lower part of the injector in the vice and dismantle injector.

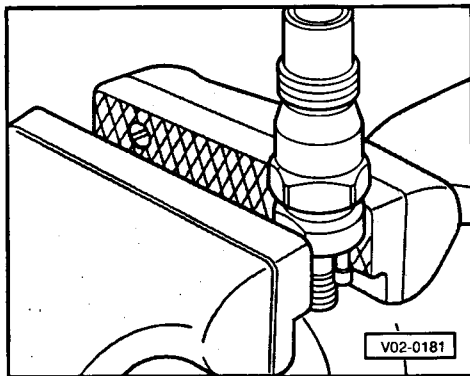
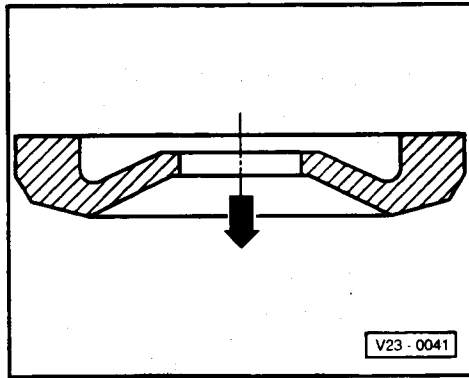

23-23

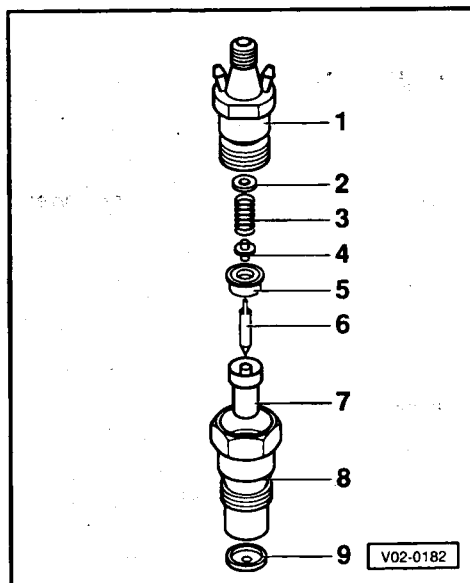

- ◀ When dismantling the injector, care should be taken that the individual parts are not interchanged.

- 1 - Upper part of injector
- 2 - Shim
- 3 - Injector spring
- 4 - Thrust pin
- 5 - Needle holder
- 6 - Injector needle
- 7 - Injector nozzle
- 8 - Lower part of injector
- 9 - Heat shield

Tightening torque:

Upper and lower part of injector 70 Nm

Checking injector needle tip

(Visual check)

If the needle tip is broken off or bent, renew injector or injector nozzle with needle.

23-24

Testing and adjusting the breaking pressure

(Using V.A.G. 1322)

- Pressure gauge switched on

Important!

When testing the injectors, take care not to expose the hands to the injector spray, as the working pressure will cause the fuel oil to penetrate the skin and cause severe injury.

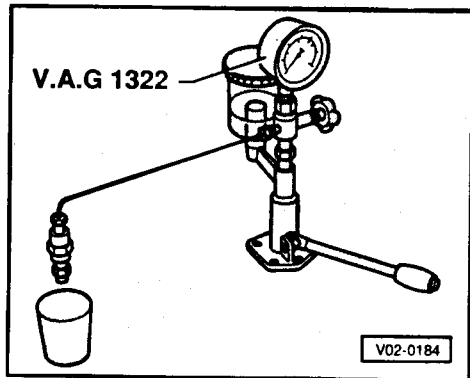

- ◀ – Move the pump hand lever slowly downwards. Watch pressure at which the injector cracks off and adjust if necessary by changing the shim.

Specified values:

Engine code	Breaking pressure	
	New injector	Wear limit
028.B, ADG	130...138 bar	120 bar
ADE	155...163 bar	140 bar

23-25

For the purposes of adjustment, shims are available in thicknesses from 1.00...1.95 mm. The shim thicknesses are graded in steps of 0.05 mm. Box 3065 should be used to store the washers.

- ◆ Thicker washer increases the breaking pressure.
- ◆ Thinner washer lowers the breaking pressure.
- ◆ Increasing the pretension by 0.05 mm increases the breaking pressure by about 5.0 bar.

Note:

When servicing used injectors, set the breaking pressure to the specified value for new injectors.

Leakage test

- Pressure gauge is switched on
- ◀ – Move pump lever down slowly and hold a pressure of about 110 bar for 10 seconds. No fuel should leak from the nozzle tip.
- Replace injector if leaking.

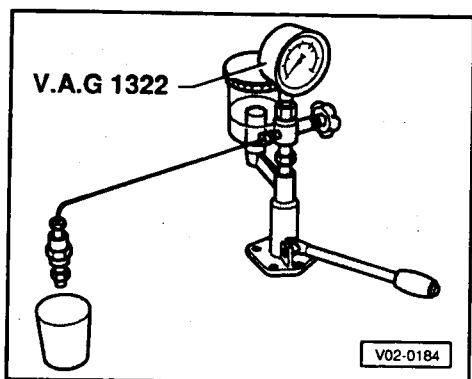

23-26

Testing alternator and voltage regulator with ballast resistance

(45 A, 65 A, 90 A alternator)

- V-belt tension, alternator security, wire routing and earth strap connections OK.

- Engine oil temperature minimum 60 °C

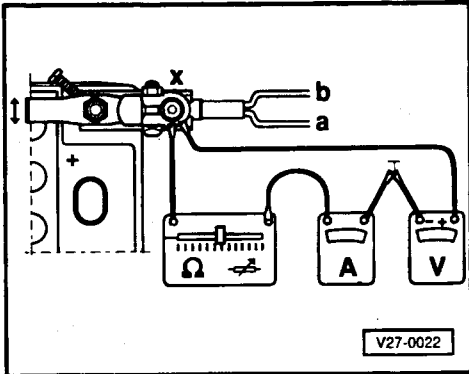

- ◀ a - To starter
- b - To glow plug relay
- x - Battery cut-out switch
- A - Ammeter 0...100 amps
- V - Volt meter 0...30 volts
- Ω - Ballast resistance

- With ignition switched off, disconnect the battery earthing strap.
- Disconnect positive terminal from battery positive terminal (+).
- Connect battery cut-out switch to the battery positive () terminal.
- Connect the positive terminal to the battery cut-out switch.
- Connect the ammeter, volt meter and ballast resistance as illustrated.

27-1

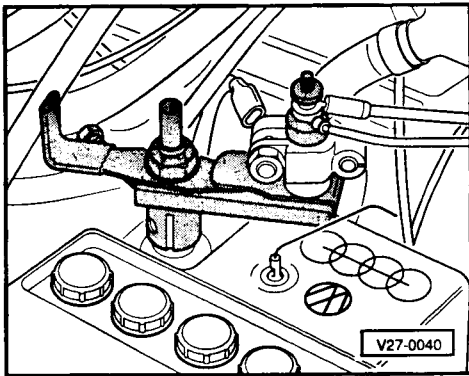

- ◀ - Connect the battery earthing strap, close the battery cut-out switch.
- Start the engine and run at increased rpm.
- Set the ballast resistance so that the ammeter indicates about 20 amps.
- Open battery cut-out switch. (This separates the battery from the test circuit. The ballast current is now controlled only by the ballast resistance.)
- Regulate the ballast resistance until the ammeter indicates
 - 30 Amps for 45 A alternator.
 - 45 Amps for 65 A alternator.
 - 60 Amps for 90 A alternator.
- Read off the voltage on the voltmeter,
 - 12V version
 - Specification: 12.5...14.5 V
 - 24V version
 - Specification: 25...29 V

- If the specifications are not attained, first change the alternator voltage regulator and repeat the measurement.
- ◆ If the specifications are then attained, the old regulator was defective.
- ◆ If the specifications are not attained, the alternator is defective. Check individual parts, and if necessary, replace. Install old regulator again.

27-3

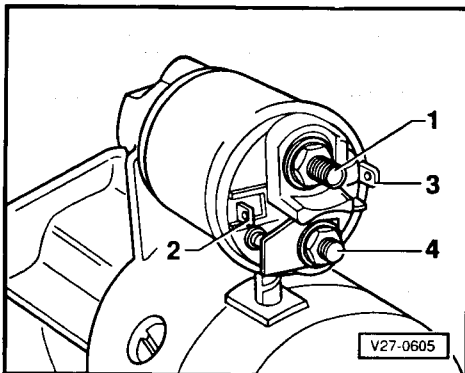

Checking starter

Cable connections to the solenoid

- 1 - Terminal 30 - from battery (+)
- 2 - Terminal 50 - from ignition/starter switch
- 3 - Connection for field winding

Starter does not turn

- Battery charged
- The cable connections to the solenoid switch and the earth strap between engine, starter motor and the battery must be tight and must not be oxidised

Note:

Measure all voltages with voltmeter, e.g. V.A.G. 1315A or V.A.G. 1526.

- Measure the voltage on terminal 50 of the starter solenoid switch -3-.
 - 12 V version:
 - Specification at least 8 V
 - 24 V version:
 - Specification at least 16 V
- If the specified value is attained, measure the voltage on the connection to the field winding -4- on the solenoid switch. (Make sure that there is a good contact.)

27-4

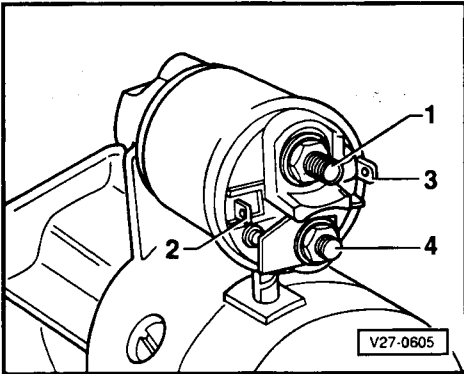

- If there is a voltage of (at least 8 V or 16 V) present, service starter.

- Otherwise, renew solenoid switch.

◀ - If the specification is not attained on terminal 50 of the solenoid switch -3-, measure the voltage on the ignition/starter switch terminal 50.

- If a voltage of (at least 8 V or 16 V) is present, repair open circuit between the ignition/starter switch terminal 50 and the starter terminal 50 (cable routing ⇒ Page 27-7, Current flow diagram).

- Otherwise, renew ignition/starter switch.

Starter turns too slowly and does not crank the engine

- Engine filled with oil appropriate to the ambient temperature during the winter season.
 - V-belt tension OK.
 - Battery charged
 - Cable connections to the battery OK. (no voltage loss due to loose or oxidised connections)
- Operate starter.

————— 27-5 —————

- If the starter does not crank the engine, disconnect the battery earth strap.

- Clean and tighten the connections to the starter and the earth strap (between the engine and unit). (Do not loosen earth strap on the unit.)

- Attach the battery earth strap.

- Operate the starter.

- If the starter does not crank the engine, the following faults can be present:

◆ Insufficient contact between the carbon brushes and the commutator

- Renew the carbon brushes and clean carbon brush guides.

◆ Commutator scored, burnt or soiled

- Renew armature.

————— 27-6 —————

Current flow diagram 12 V, 24 V

Note:

The wiring cross-sections given are minimum sizes. Some units have larger sizes and these should be noted when carrying out repairs.

- A - Battery
- B - Starter
- C - Alternator
- D - Ignition/starter switch
- F14 - Coolant temperature warning switch (110°C)
- F22 - Oil pressure switch (0.3 bar)
- G27 - Engine temperature sender
- J52 - Glow plug relay
- K2 - Alternator warning lamp

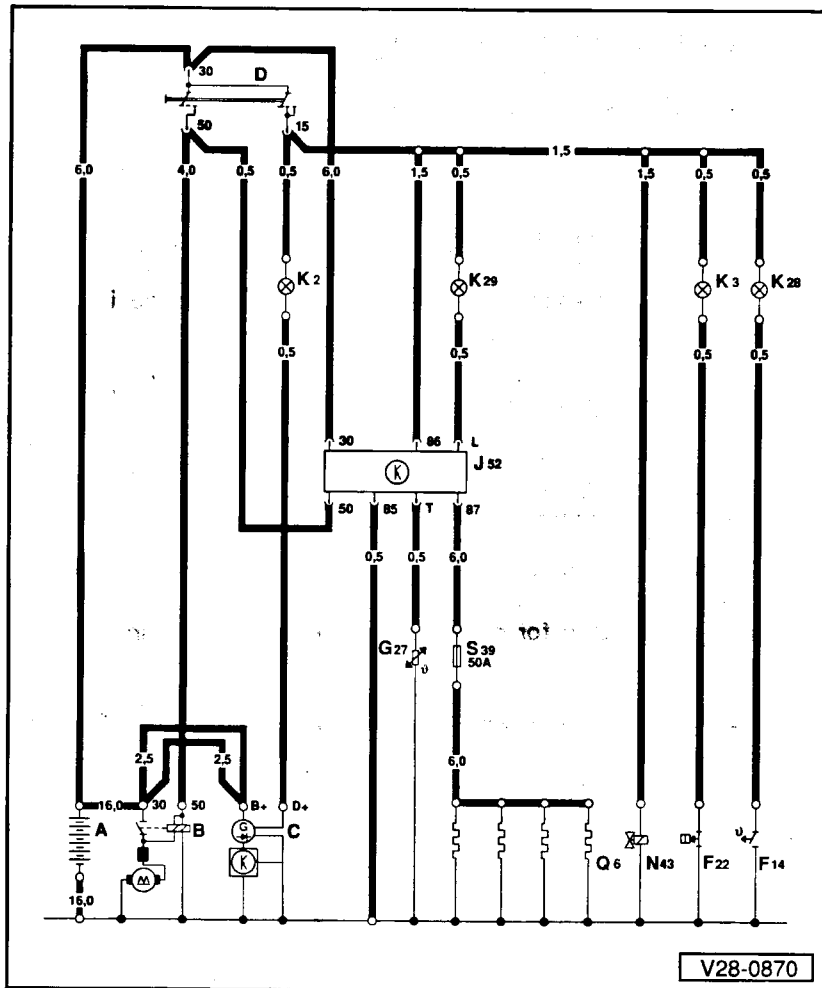

27-7

- K3 - Oil pressure warning lamp
- K28 - Coolant temperature warning lamp
- K29 - Glow period warning lamp
- N43 - Electromagnetic cut-off
- Q6 - Glow plug
- S39 - Glow plug strip fuse (50A)

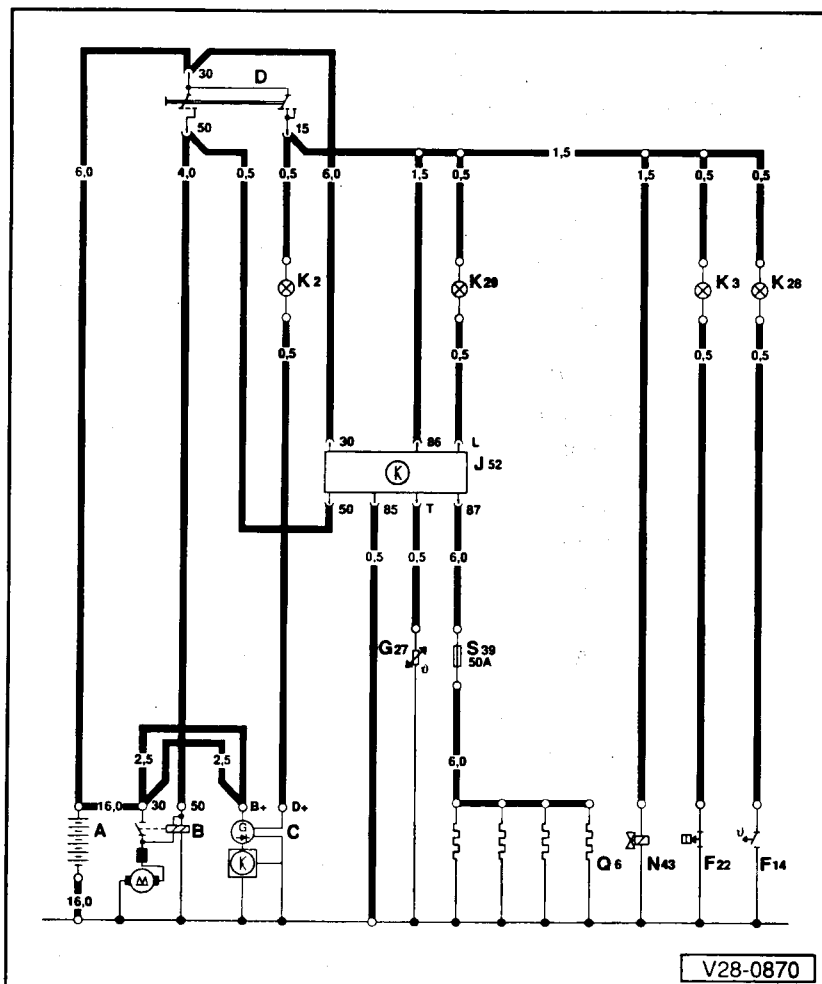

27-8

Checking glow plug system

Test prerequisites

- Engine cold
- Battery voltage OK.
- Voltage present at glow plugs. If no voltage is present, locate fault using Current flow diagram ⇒ Page 27-7.

Checking glow plug current draw with V.A.G 1315A

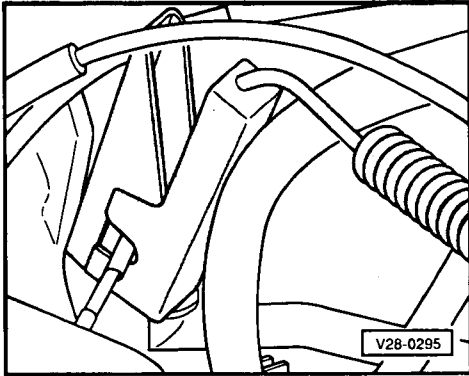

- Connect tester to the current supply.
- ◀ - Place glow plug supply wire in the current pick-up clamp.
- Press button for current measurement with current pick-up clamp.
- Pull electric wire off engine temperature sender (G 27).
- Turn ignition key to preglow for a maximum of 15 seconds.

28-1

Note:

♦ After the rapid glow system has stabilised the current draw of the glow plugs should be
12V version: about 12 A
24V version: about 6 A
per glow plug.

♦ The current specification will only be attained with a battery voltage in excess of
12 V version: 11.5 V.
24 V version: 23 V.

- Read off the current draw.
12V version:
Specification about 48 A
24V version:
Specification about 24 A

With a current draw for the glow plugs of

12V version:

- about 36 A - one glow plug defective
- about 24 A - two glow plugs defective
- about 12 A - three glow plugs defective
- about 0 A - all glow plugs defective

24 V version:

- about 18 A - one glow plug defective
- about 12 A - two glow plugs defective
- about 6 A - three glow plugs defective
- about 0 A - all glow plugs defective

28-2

Checking glow plugs

- Remove power supply wire and busbar for glow plugs.
- Connect diode test lamp V.A.G. 1527 to battery positive (+) and to each glow plug in turn.

Led lights up: Glow plug OK.

Led does not light up:

- Replace glow plug
Tightening torque: 25 Nm

Note:

- ◆ *The glow plug tightening torque of 25 Nm must not be exceeded, otherwise, the ring gap between the glow pin and thread will be squeezed together. This can cause the glow plugs to fail prematurely.*
- ◆ *If no defects are found, and the engine is still hard to start, the glow plugs must be visually checked (injectors removed) while glowing.*

28-3

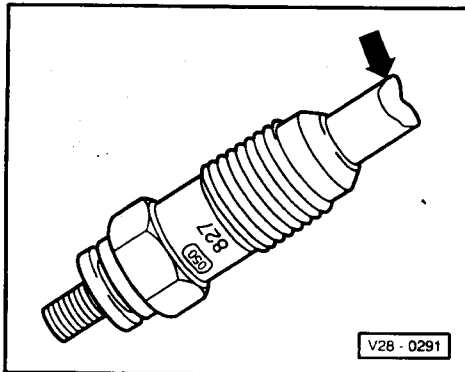

Glow plugs with burnt electrodes

- ◀ Burnt glow plugs electrodes are frequently caused by faulty injectors. Damage of this type is not due to faults in or on the glow plugs.

When damage of this nature is found - arrow - it is not sufficient to simply renew the glow plug. The injectors must also be tested for nozzle breaking pressure and leakage
⇒ Page 23-23, Servicing injectors.

28-4

